

Department of Social Systems and Management

Discussion Paper Series

No. 1206

**Structural Analysis of Two Person Game with Mixed
Strategy for Energy Supply**

by

Kazuki Takahashi and Ushio Sumita

May 2008

UNIVERSITY OF TSUKUBA
Tsukuba, Ibaraki 305-8573
JAPAN

STRUCTURAL ANALYSIS OF TWO PERSON GAME WITH MIXED STRATEGY FOR ENERGY SUPPLY

Kazuki Takahashi*

Tokyo Gas Co., Ltd.

Ushio Sumita†

University of Tsukuba

* Mathematical Science and Marketing Section, Technology Planning Department,
Tokyo Gas Co., Ltd, 5-2, Kaigan 1-Chome, Minatoku, Tokyo 105-8527, Japan.

kazuki@tokyo-gas.co.jp

† Graduate school of Systems and Information Engineering, University of Tsukuba,
1-1-1, Tennoudai, Tsukuba, Ibaraki, 305-8573, Japan,

sumita@sk.tsukuba.ac.jp

May 14, 2008

Abstract Structural models for analyzing competitive markets characterized by homogeneous products and services such as the energy supply can be traced back to 1920's. To the authors' best knowledge, the literature focuses on pure strategies and analysis for mixed strategies are largely ignored. However, the characteristic of the energy supply often allows only mixed strategies as a meaningful basis for analyzing the price competition. The purpose of this paper is to fill this gap by developing a duopoly model with two symmetric customers allowing mixed strategies. Nash equilibriums are constructed explicitly when mixed strategies are defined on a finite set of L discrete points spread in a finite interval and their reciprocals are equally distanced. Those equilibriums consist of two different types. One is that two players offer the same strategy, and the other is that each player takes the strategy different from the other. Limiting strategies as $L \rightarrow \infty$ are derived explicitly. These limiting strategies are also shown to be Nash equilibriums in the context of mixed strategies defined on continuum.

Keywords: Energy, two person game, mixed strategy, limiting strategy

1. Introduction

While the price strategy plays a significant role in any business, it is of crucial importance to the energy supply industry such as city gas and propane gas because of several reasons. Firstly the energy supply industry provides homogeneous products across different suppliers. Large-scale industrial customers for example are quite sensitive to prices of the energy they need. Although service quality for energy consulting, security and the like would be quite important for such industrial customers, because of the product homogeneity, the price strategy of a supplier is the key to differentiate the company from the rest and to establish its competitiveness in the market.

A second reason to emphasize the price strategy in the energy supply industry can be found in that the industry has been deregulated in many advanced countries since near the end of the previous century, including the United States, EU countries and Japan. The deregulation is intended to device a variety of ways to lower barrier for new entry and the industry has been exposed to rapidly growing severe price competitions.

Lastly, it is important to realize that the energy supply industry still faces certain customs for price setting which come from the public nature of the industry. Before the deregulation in Japan, for example, it is customary to offer a common price table, called the universal price table, to all customers at their site, provided that the total demand, and

hourly and monthly load factors over a year are more or less the same. In addition, the universal price table cannot be altered frequently, say at most once in a few years. Such practices concerning the price strategy are still in effect to some extent even after the deregulation.

Structural models for analyzing competitive markets characterized by homogeneous products and services such as the public utility can be traced back to 1920's. The original paper by Hotelling [5] deals with the duopoly situation where two suppliers compete over customers uniformly distributed on a finite line by choosing their locations and prices. D'Aspremont et al. [2] show non-existence of Nash equilibrium unless the two suppliers are located relatively far apart. Economides [3] extended the Hotelling model by introducing customers uniformly distributed on a plane. Anderson [1] incorporates stackelberg leadership within the context of the Hotelling model. Other variations include Thisse and Vives [9], Zhang and Teraoka [10] and Rath [8]. Gabszewicz and Thisse [4] provide an excellent review of the literature. More recently, for a spatially duopoly model with customers located at different nodes having separate demand functions, Matsubayashi et al. [7] establish a necessary and sufficient condition for the existence of Nash equilibrium and develop computational algorithms for finding the equilibrium point.

The literature discussed above focuses on pure strategies and analysis for mixed strategies has been largely ignored, to the best knowledge of the authors. Since the universal price table is still in effect to some extent and cannot be altered easily once they are set for a certain period even after the deregulation in Japan, it is of crucial importance to consider mixed strategies by reading the price strategies of competitors at the time of bidding. This means that the role of mixed strategies has been increasing its importance in analyzing the energy supply industry.

The purpose of this paper is to fill this gap by developing a duopoly model with two symmetric customers and to construct the Nash equilibriums explicitly when mixed strategies are defined on a finite set of L discrete points that are chosen in such a way that their reciprocals are equally distanced in a finite interval. The limiting strategies as $L \rightarrow \infty$ are also derived explicitly. It is shown that these limiting strategies are Nash equilibriums within the context of mixed strategies defined on continuum.

The structure of this paper is as follows. In Section 2, a duopoly model with two symmetric customers is introduced and a game-theoretic framework is described formally. By choosing discrete pricing points in a peculiar way, the Nash equilibriums are constructed explicitly in Section 3. Section 4 is devoted to analyze the limiting behavior of the strategies derived in Section 3 as $L \rightarrow \infty$. In the last section, numerical examples are presented.

2. Model Description

We consider a market consisting of two suppliers and two customers, where each supplier provides a homogeneous service such as propane gas or natural gas transported by LNG tank lorry for industrial use. Each customer may represent one large industry or a group of residents in the same district. For convenience, the near customer of supplier i is defined as customer i and the distant customer as customer $3 - i$, $i = 1, 2$ as depicted in Figure 2.1. The market is assumed to be symmetric in that a) both suppliers have the same costs c_{high} and c_{low} for providing service to the distant customer and the near customer respectively

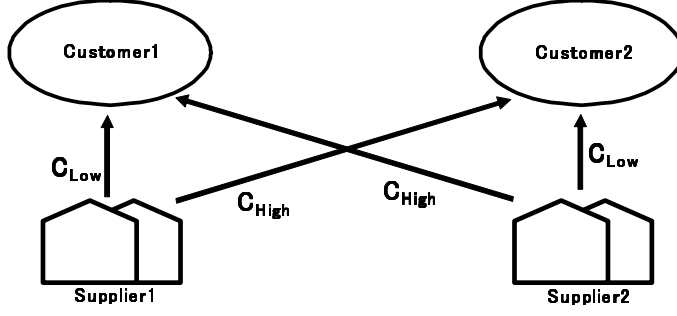

Figure 2.1: Two Supplier Two Customer Model

where $c_{low} < c_{high}$; b) both customers have the same demand D ; and c) each supplier has to offer a uniform price upon delivery to both of the two customers despite the cost difference. Each supplier provides its service only when it results in a positive return to do so and each customer chooses the supplier which offers the lower price. When the two suppliers happen to offer the same price to a customer, the demand of the customer is split evenly between the two suppliers. Since the service under consideration is typically an energy supply service, it is also natural to assume that there exists a price upper bound. It should be noted that, if $c_{low} < \pi_i \leq c_{high}$, supplier i monopolizes its near customer and the price can be increased to c_{high} without losing its monopoly of the near customer. Accordingly, one has $\pi_i \in I = [c_{high}, U]$ for $i = 1, 2$ where π_i is the uniform price offered by supplier i . In what follows, we describe a general game structure defined on the strategy set I .

Let (Ω, \mathcal{F}, P) be a probability space, and let RV be a set of random variables defined on (Ω, \mathcal{F}, P) with full support on $I = [c_{high}, U]$. More specifically, for $A_X(\alpha) = \{\omega | X(\omega) \leq \alpha\}$, we define $RV = \{X | X : \Omega \rightarrow \mathcal{R}, A_X(\alpha) \in \mathcal{F} \text{ for } \forall \alpha \in \mathcal{R}\}$ where \mathcal{R} is the set of real numbers. It should be noted that, for any $A \subset \mathcal{R}$, we write $P[X \in A] = \int_{\omega \in \Omega} \delta_{\{X(\omega) \in A\}} P(d\omega)$ where $\delta_{\{X(\omega) \in A\}} = 1$ if $X(\omega) \in A$ and 0 else. In particular, it should be noted that $P[X \in I] = 1$. A mixed strategy of supplier i then corresponds to a random variable $X_i \in RV$. Throughout the paper we assume that each supplier decides its strategy independently of the other so that X_1 and X_2 are independent, and each supplier has enough production capacity to meet customers' demands.

Given $\pi_1 = X_1(\omega_1)$ and $\pi_2 = X_2(\omega_2)$ for some $\omega_1, \omega_2 \in \Omega$, it can be readily seen that the payoff function of supplier i is given by

$$h_i(\pi_1, \pi_2) = \begin{cases} 2(\pi_i - c_{mid})D & \text{if } \pi_i < \pi_{3-i}, \quad \pi_i, \pi_{3-i} \in (c_{high}, U] \\ (\pi_i - c_{mid})D & \text{if } \pi_i = \pi_{3-i}, \quad \pi_i, \pi_{3-i} \in (c_{high}, U] \\ 0 & \text{if } \pi_i > \pi_{3-i}, \quad \pi_i, \pi_{3-i} \in (c_{high}, U] \\ (c_{high} - c_{low})D & \text{if } \pi_i = c_{high}, \quad \pi_{3-i} \in (c_{high}, U] \\ (\pi_i - c_{low})D & \text{if } \pi_i \in (c_{high}, U], \quad \pi_{3-i} = c_{high} \end{cases}, \quad (2.1)$$

where $c_{mid} \stackrel{\text{def}}{=} (c_{low} + c_{high})/2$.

If $c_{high} < \pi_i < \pi_{3-i} \leq U$, supplier i can monopolize the entire market with demand $2D$ at the average earning per unit of $\pi_i - c_{mid}$. When $c_{high} < \pi_i = \pi_{3-i} \leq U$, the demand D of each customer is split evenly between the two suppliers and the average earning per unit is again $\pi_i - c_{mid}$. The case that $c_{high} < \pi_{3-i} < \pi_i \leq U$ is the opposite of the

first case and the competitor of supplier i monopolizes the entire market. For the case of $c_{high} = \pi_i < \pi_{3-i} \leq U$, supplier i can not produce a positive profit from the distant customer and therefore captures only the near customer with average earning per unit of $c_{high} - c_{low}$. Finally, if $c_{high} = \pi_{3-i} < \pi_i \leq u$, supplier i is forced to settle for the near customer with the average earning per unit of $\pi_i - c_{low}$.

Let S_i be the strategy set of supplier i and define $S = S_1 \times S_2$. In our model, one has $S_1 = S_2 = RV$ so that $S = RV \times RV$. Given $(X_1, X_2) \in S$, let $V_i(X_1, X_2) = E[h_i(X_1, X_2)]$ be the expected payoff function of supplier i . More specifically, we define

$$V_i(X_1, X_2) = \int \int_{\omega_1 \in \Omega \ \omega_2 \in \Omega} h_i(X_1(\omega_1), X_2(\omega_2)) P(d\omega_1) P(d\omega_2), \quad i = 1, 2. \quad (2.2)$$

The following conventional notion in game theory is employed.

Definition 2.1

- a) For $i = 1, 2$, X_i^* is a best reply against X_{3-i} if $V_1(X_1^*, X_2) = \max_{X_1 \in RV} [V_1(X_1, X_2)]$ for $i = 1$ and $V_2(X_1, X_2^*) = \max_{X_2 \in RV} [V_2(X_1, X_2)]$ for $i = 2$.
- b) For $i = 1, 2$, $B_i(X_{3-i}) = \{X_i^* : X_i^* \text{ is a best reply against } X_{3-i}\}$ is called the set of best replies of supplier i against X_{3-i} .
- c) The best reply correspondence $B : S \rightarrow S$ is defined as $B(X_1, X_2) = B_1(X_2) \times B_2(X_1)$.
- d) (X_1^*, X_2^*) is a Nash equilibrium, denoted by $(X_1^*, X_2^*) \in \mathcal{NE}$, if and only if $(X_1^*, X_2^*) \in B(X_1^*, X_2^*)$.

In the following sections we derive two types of Nash equilibriums for mixed strategies explicitly. First we focus on discrete random variables in RV when the discrete support points are chosen in such a way that their reciprocals are separated by equal distance, and two types of Nash equilibriums for the discretized game are constructed explicitly. It is shown that the sequence of each type of Nash equilibriums converges in law to a mixed strategy in S as the equal distance diminishes to 0. Furthermore, it can be shown that the limiting mixed strategies are also the Nash equilibriums for the original game defined on continuum. It may be worthwhile to note that the number of Nash equilibriums is odd for almost all bimatrix games as demonstrated in Lemke [6].

3. Nash Equilibriums with Specific Discrete Support

In this section, we provide a constructive proof for the existence of Nash equilibriums by discretizing the game defined in Section 2. Let $\underline{a} = [a_1, \dots, a_L]^T \in \mathcal{R}^L$ be such that

$$a_1 = (c_{high} - c_{mid})D \quad ; \quad (3.1)$$

$$\frac{1}{a_m} = (L - m)\Delta + \frac{1}{a_L}, m \in \mathcal{L} \setminus \{1\} \quad ; \text{ and} \quad (3.2)$$

$$a_L = (U - c_{mid})D \quad , \quad (3.3)$$

$$\text{where } K = \frac{1}{a_1} - \frac{1}{a_L}, \quad \Delta = \frac{K}{L - \frac{3}{2}} \quad . \quad (3.4)$$

It should be noted that \underline{a} is constructed in such a way that

$$\frac{1}{a_m} - \frac{1}{a_{m+1}} = \Delta, \quad m \in \mathcal{L} \setminus \{1, L\} \quad ; \quad \frac{1}{a_1} - \frac{1}{a_2} = \frac{1}{2}\Delta \quad . \quad (3.5)$$

We now define $\underline{v}_L = [v_1, \dots, v_L] \in \mathcal{R}^L$ in terms of \underline{a} as

$$\underline{v}_L = \frac{1}{D}\underline{a} + c_{mid}\underline{1}_L \quad , \quad (3.6)$$

where $\underline{1}_m$ is the m -dimensional vector whose components are all 1. We note that $v_1 = c_{high} < v_2 < v_3 < \dots < v_{L-1} < v_L = U$. Let $DRV(\underline{v}_L)$ be a set of discrete random variables with full support on $\{v_1, \dots, v_L\}$, where $X \in DRV(\underline{v}_L)$ is represented by a probability vector \underline{q} with $P[X = v_m] = q_m$, $m \in \mathcal{L} = \{1, 2, 3, \dots, L\}$, and we write $X \in DRV(\underline{v}_L)$ or $\underline{q} \in DRV(\underline{v}_L)$ interchangeably.

In this section, we focus on discrete mixed strategies in $S(\underline{v}_L) = DRV(\underline{v}_L) \times DRV(\underline{v}_L)$, where Definition 2.1 should be rewritten with RV replaced by $DRV(\underline{v}_L)$. The decomposition of the interval $[c_{high}, U]$ by \underline{v}_L is rather peculiar as depicted in Figure 3.1. Let

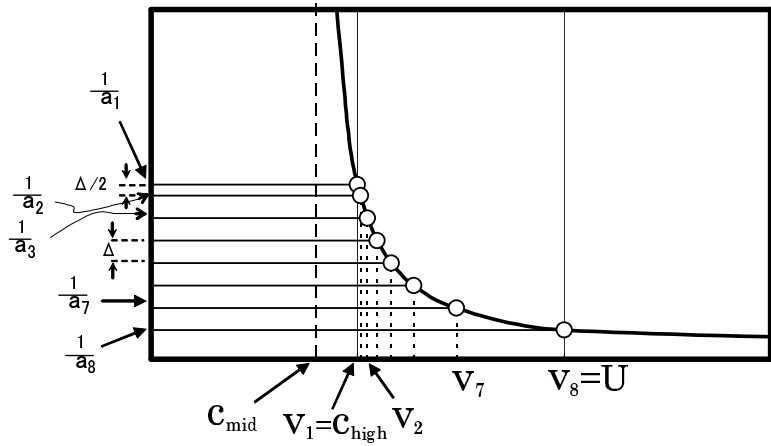

Figure 3.1: \underline{v}_L with $L=8$

$\underline{H}_i = [h_i(v_m, v_n)]_{m,n \in \mathcal{L}}$, $i = 1, 2$ with $h_i(v_m, v_n)$ as given in (2.1). From (2.2), one sees that $V_i(\underline{q}_1, \underline{q}_2) = \underline{q}_1^T \underline{H}_i \underline{q}_2$, $i = 1, 2$. From the symmetric structure of (2.1), it can be seen that $h_1(\pi_1, \pi_2) = h_2(\pi_2, \pi_1)$ so that $\underline{H}_2 = \underline{H}_1^T$. It then follows that $V_2(\underline{q}_1, \underline{q}_2) = \underline{q}_1^T \underline{H}_2 \underline{q}_2 = \underline{q}_2^T \underline{H}_1^T \underline{q}_1 = \underline{q}_2^T \underline{H}_1 \underline{q}_1$. Hence, it is possible to define $V_i(\underline{q}_1, \underline{q}_2)$ as

$$V_i(\underline{q}_1, \underline{q}_2) = \underline{q}_i^T \underline{H}_i \underline{q}_{3-i} \quad \text{for } i = 1, 2 \quad \text{where } \underline{H}_i \stackrel{def}{=} [h_i(v_m, v_n)]_{m,n \in \mathcal{L}} = \underline{H}_1 \quad . \quad (3.7)$$

In what follows, we show in a constructive manner that there exist two types of Nash equilibriums $(\underline{q}_1^*, \underline{q}_2^*), (\underline{q}_1^{**}, \underline{q}_2^{**}) \in \mathcal{NE}(\underline{v}_L)$ where the two suppliers offer the same price with the same expected profit value in the former case (i.e. $\underline{q}_1^* = \underline{q}_2^*$), while they offer different prices but have the same expected profit value in the latter case (i.e. $\underline{q}_1^{**} \neq \underline{q}_2^{**}$). We first construct \underline{q}^* satisfying $\underline{q}_1^* = \underline{q}_2^* = \underline{q}^*$ and $(\underline{q}_1^*, \underline{q}_2^*) \in \mathcal{NE}(\underline{v}_L)$. A few preliminary lemmas are needed and proofs are given in Appendix.

Lemma 3.1 Let Δ be as in (3.4) and define $\underline{q}^{*T} = [\alpha_1, \alpha_2 \underline{1}_{L-1}^T] \in \mathcal{R}^L$ where

$$\alpha_1 = \frac{2a_1}{C_1} \left(\frac{2}{a_L} - \Delta \right) , \quad \alpha_2 = \frac{2a_1}{C_1} \Delta , \quad \text{and} \quad C_1 = 2 \left(\frac{a_1}{a_L} + 1 \right) - a_1 \Delta \quad . \quad (3.8)$$

If $L > \max(2, \frac{a_L}{2a_1} + 1)$, then $\underline{q}^* > \underline{0}$ and $\underline{q}^{*T} \underline{1}_L = 1$.

Lemma 3.2 Let α_1, α_2 and C_1 be as in Lemma 3.1. Then one has

$$\begin{aligned} a) \quad & 2\alpha_2 + a_1(\alpha_1 - 2)\Delta = 0 ; \quad \text{and} \\ b) \quad & \alpha_2 + a_1(\alpha_1 - 2)\frac{1}{a_L} + \alpha_1 = 0 \quad . \end{aligned}$$

For notational convenience, the following matrices are introduced. We note that $\delta_{\{ST\}} = 1$ if the statement ST holds and $\delta_{\{ST\}} = 0$ else.

$$\underline{\underline{I}} = [\delta_{\{m=n\}}]_{m,n \in \mathcal{L} \setminus \{L\}} \in \mathcal{R}^{(L-1) \times (L-1)} \quad (3.9)$$

$$\underline{\underline{A}}_D = [\delta_{\{m=n\}} a_{m+1}]_{m,n \in \mathcal{L} \setminus \{L\}} \in \mathcal{R}^{(L-1) \times (L-1)} \quad (3.10)$$

$$\underline{\underline{L}} = [\delta_{\{m < n\}}]_{m,n \in \mathcal{L} \setminus \{L\}} \in \mathcal{R}^{(L-1) \times (L-1)} \quad (3.11)$$

$$\underline{\underline{L}}_{\perp 1} = [\delta_{\{m+1=n\}}]_{m,n \in \mathcal{L} \setminus \{L\}} \in \mathcal{R}^{(L-1) \times (L-1)} \quad (3.12)$$

$$\underline{\underline{B}} = \underline{\underline{I}} + \underline{\underline{L}} \in \mathcal{R}^{(L-1) \times (L-1)} \quad (3.13)$$

$$\underline{\underline{C}} = \underline{\underline{I}} + 2\underline{\underline{L}} \in \mathcal{R}^{(L-1) \times (L-1)} \quad (3.14)$$

$\hat{\underline{e}}_m \in \mathcal{R}^{L-1}$ and $\underline{e}_m \in \mathcal{R}^L$ are the m -th unit vectors in \mathcal{R}^{L-1} and \mathcal{R}^L respectively

$$\underline{w}(x, y) = x\underline{1}_{L-1} + (y - x)\hat{\underline{e}}_{L-1} \in \mathcal{R}^{(L-1)} \quad (3.15)$$

Lemma 3.3 Let $\underline{\underline{A}}_D$ and $\underline{\underline{B}}$ be as in (3.10) and (3.13) respectively. Then one has

$$\begin{aligned} a) \quad & \underline{\underline{B}}^{-1} \underline{\underline{A}}_D^{-1} \underline{1}_{L-1} = \underline{w}(\Delta, \frac{1}{a_L}) ; \quad \text{and} \\ b) \quad & \underline{\underline{B}}^{-1} \underline{\underline{C}} \underline{1}_{L-1} = \underline{w}(2, 1) \quad . \end{aligned}$$

Lemma 3.4 Let $\underline{\underline{H}}$ be as in (3.7) and define $\underline{v}_L^T = [v_1, \dots, v_L]$ as in (3.6). Then the following statements hold true.

$$\begin{aligned} a) \quad & [\underline{\underline{H}}]_{1,m} = 2a_1 \text{ for } m \in \mathcal{L} \\ b) \quad & [\underline{\underline{H}}]_{n,1} = a_1 + a_n \text{ for } n \in \mathcal{L} \setminus \{1\} \\ c) \quad & [\underline{\underline{H}}]_{m,n} = [\underline{\underline{A}}_D \underline{\underline{C}}]_{m-1,n-1} \text{ for } m, n \in \mathcal{L} \setminus \{1\} \\ d) \quad & \underline{\underline{H}} = \begin{bmatrix} 2a_1 & 2a_1 \underline{1}_{L-1}^T \\ (a_1 \underline{\underline{I}} + \underline{\underline{A}}_D) \underline{1}_{L-1} & \underline{\underline{A}}_D \underline{\underline{C}} \end{bmatrix} \\ e) \quad & \underline{\underline{H}} \begin{bmatrix} x \\ y \underline{1}_{L-1} \end{bmatrix} = \begin{bmatrix} 2a_1 \\ (y \underline{\underline{A}}_D \underline{\underline{C}} + x a_1 \underline{\underline{I}} + x \underline{\underline{A}}_D) \underline{1}_{L-1} \end{bmatrix} \\ & \text{where } 0 < x < 1, \text{ and } y = (1 - x)/(L - 1) \end{aligned}$$

The main theorem of this section can now be proven.

Theorem 3.5 Let $\alpha_i (i = 1, 2)$ be as in (3.8) and define $\underline{q}_1^* = \underline{q}_2^* = \underline{q}^*$ where $\underline{q}^{*T} = [\alpha_1, \alpha_2 \underline{1}_{L-1}^T]$. If $L > \max\{2, \frac{\alpha_L}{2a_1} + 1\}$, then $(\underline{q}_1^*, \underline{q}_2^*) \in \mathcal{NE}(\underline{v}_L)$. Furthermore, the payoff values of the two suppliers are equal with $V_1(\underline{q}_1^*, \underline{q}_2^*) = V_2(\underline{q}_1^*, \underline{q}_2^*) = D(c_{high} - c_{low})$.

Proof: From Lemma 3.1, one sees that $\underline{q}^* \in DRV(\underline{v}_L)$. In order to prove $(\underline{q}_1^*, \underline{q}_2^*) \in \mathcal{NE}(\underline{v}_L)$, from (3.7), all we need to show is that $V_1(\underline{e}_m, \underline{q}_2^*) \leq V_1(\underline{q}_1^*, \underline{q}_2^*)$ and $V_2(\underline{q}_1^*, \underline{e}_m) \leq V_2(\underline{q}_1^*, \underline{q}_2^*)$ hold for all $m \in \mathcal{L}$. From (3.15), one sees that $\underline{w}(x, y)$ is linear in (x, y) . Lemma 3.2 then implies that $\alpha_2 \underline{w}(2, 1) + a_1(\alpha_1 - 2) \underline{w}(\Delta, \frac{1}{a_L}) + \alpha_1 \underline{w}(0, 1) = \underline{w}[2\alpha_2 + a_1(\alpha_1 - 2)\Delta, \alpha_2 + a_1(\alpha_1 - 2)\frac{1}{a_L} +$

$\alpha_1] = \underline{w}(0, 0) = \underline{0}$. With $\underline{w}(2, 1)$ and $\underline{w}(\Delta, \frac{1}{a_L})$ in the above equation substituted by Lemma 3.3 a) and b) respectively, one sees that $\alpha_2 \underline{B}^{-1} \underline{C} \underline{1}_{L-1} + a_1(\alpha_1 - 2) \underline{B}^{-1} \underline{A}_D^{-1} \underline{1}_{L-1} + \alpha_1 \underline{w}(0, 1) = \underline{0}$. Multiplying $\underline{A}_D \underline{B}$ from left, this then leads to

$$\alpha_2 \underline{A}_D \underline{B} \underline{B}^{-1} \underline{C} \underline{1}_{L-1} + a_1(\alpha_1 - 2) \underline{1}_{L-1} + \alpha_1 \underline{A}_D \underline{B} \underline{w}(0, 1) = \underline{0},$$

i.e.

$$[\alpha_2 \underline{A}_D \underline{C} + a_1 \alpha_1 \underline{I} + \alpha_1 \underline{A}_D] \underline{1}_{L-1} = 2a_1 \underline{1}_{L-1}, \quad (3.16)$$

where $\underline{B} \underline{w}(0, 1) = \underline{1}_{L-1}$ is employed to yield (3.16). On the other hand, from Lemma 3.4 d), one sees that $\underline{H} \underline{q}^* = \begin{bmatrix} 2a_1 \\ (\alpha_2 \underline{A}_D \underline{C} + \alpha_1 a_1 \underline{I} + \alpha_1 \underline{A}_D) \underline{1}_{L-1} \end{bmatrix}$. It then follows from this and (3.16) that $\underline{H} \underline{q}^* = 2a_1 \underline{1}_L$. This in turn implies that $V_1(\underline{e}_m, \underline{q}_2^*) = 2a_1 = V_1(\underline{q}_1^*, \underline{q}_2^*)$ and $V_2(\underline{q}_1^*, \underline{e}_m) = 2a_1 = V_2(\underline{q}_1^*, \underline{q}_2^*)$ hold for all $m \in \mathcal{L}$, completing the proof. \square

The above theorem states that a Nash equilibrium can be achieved when the two suppliers offer the same mixed strategy $\underline{q}^{*T} = [\alpha_1, \alpha_2 \underline{1}_{L-1}^T] \in DRV(\underline{v}_L)$. As can be seen from (3.4), Δ decreases as L increases. One then sees from (3.8) that α_1 is much larger than α_2 for large values of L . In this case, the two suppliers tend to protect the near customer by assigning a higher probability of α_1 to $v_1 = c_{high}$. At the same time, it is crucial to allocate a small but positive probability α_2 to all other price alternatives so that $(\underline{q}_1^*, \underline{q}_2^*) \in \mathcal{NE}(\underline{v}_L)$ can be assured. Somewhat surprisingly, we next show that there exists a different type of Nash equilibrium $(\underline{q}_1^{**}, \underline{q}_2^{**}) \in \mathcal{NE}(\underline{v}_L)$, where the two suppliers take different mixed strategies (i.e. $\underline{q}_1^{**} \neq \underline{q}_2^{**}$) but share almost the same expected payoff, and one of the two player's payoff is the same as that of Theorem 3.5. As before, a few preliminary lemmas are needed and proofs are given in Appendix.

Lemma 3.6 *Let α_3 and α_4 be defined by*

$$\alpha_3 = \frac{\frac{2}{a_L}}{\frac{1}{a_1} + \frac{1}{a_L}}, \quad \text{and} \quad \alpha_4 = \frac{2\Delta}{\frac{1}{a_1} + \frac{1}{a_L}}. \quad (3.17)$$

Then one has a) $\alpha_3 = a_1(2 - \alpha_3)\frac{1}{a_L}$ and b) $\alpha_4 = a_1(2 - \alpha_3)\Delta$.

In what follows, the matrices in (3.9) through (3.14) are employed.

Lemma 3.7 *Let \underline{H} be as in (3.7) and define \underline{v}_L as in (3.6). We also define $\underline{f} \in \mathcal{R}^{L-1}$ as $(\underline{f})_m = \{1 + (-1)^m\}/2, m \in \mathcal{L} \setminus \{L\}$. If L is even, then for any $0 < x < 1$ and $y = 2(1 - x)/(L - 2)$, one has*

$$\underline{H} \begin{bmatrix} x \\ y \underline{f} \end{bmatrix} = \begin{bmatrix} 2a_1 \\ y \underline{A}_D \underline{C} \underline{f} + x a_1 \underline{1} + x \underline{A}_D \underline{1} \end{bmatrix}.$$

Lemma 3.8 *Let \underline{H} , \underline{v}_L and $\underline{w}(x, y)$ be as in (3.7), (3.6) and (3.15) respectively. Then for any $0 < y < 1$ and $x = (1 - y)/(L - 2)$, one has*

$$\underline{H} \begin{bmatrix} 0 \\ \underline{w}(x, y) \end{bmatrix} = \begin{bmatrix} 2a_1 \\ \underline{A}_D \underline{C} \underline{w}(x, y) \end{bmatrix}.$$

Lemma 3.9 *Let \underline{f} be as in Lemma 3.7. If L is even, then one has a) $\underline{B}^{-1} \underline{C} \underline{f} = \underline{w}(1, 0)$ and b) $\underline{B}^{-1} \underline{1} = \underline{w}(0, 1)$.*

We are now in a position to prove the following theorem.

Theorem 3.10 *Let α_3 and α_4 be as in Lemma 3.6. For $\underline{f} \in \mathcal{R}^{L-1}$ given in Lemma 3.7, we define $(\underline{q}_1^{**}, \underline{q}_2^{**})$ as $\underline{q}_i^{**} = \underline{q}^\sharp$, $\underline{q}_{3-i}^{**} = \underline{q}^\dagger$ where*

$$\begin{aligned} \underline{q}^\sharp{}^T &= \frac{4}{4-\alpha_4}[\alpha_3, \alpha_4 \underline{f}^T], \quad \underline{q}^\dagger{}^T = [0, \underline{w}^T(\alpha_5, \alpha_6)], \\ \alpha_5 &= a_1 \Delta \quad \text{and} \quad \alpha_6 = a_1 \left(\frac{1}{a_L} + \frac{\Delta}{2} \right). \end{aligned} \quad (3.18)$$

If L is even and $L > \max(2, \frac{a_L}{2a_1} + 1)$, then $(\underline{q}_1^{**}, \underline{q}_2^{**}) \in \mathcal{NE}(\underline{v}_L)$. The payoff values of the two suppliers at this equilibrium are given as $V_i(\underline{q}_1^{**}, \underline{q}_2^{**}) = D(c_{high} - c_{low})$, $V_{3-i}(\underline{q}_1^{**}, \underline{q}_2^{**}) = \frac{4}{4-\alpha_4}D(c_{high} - c_{low})$, $i = 1, 2$.

Proof: Without loss of generality we assume $i = 1$. First we show that $\underline{q}_1^{**}, \underline{q}_2^{**} \in DRV(\underline{v}_L)$.

It can be seen from (3.17) that $\alpha_3 + \frac{L-2}{2}\alpha_4 = (\alpha_3 + \frac{L-\frac{3}{2}}{2}\alpha_4) - \frac{1}{4}\alpha_4 = 1 - \frac{1}{4}\alpha_4$, so that $\underline{q}_1^{**T} \underline{1}_L = \frac{4}{4-\alpha_4}(\alpha_3 + \alpha_4 \underline{f}^T \underline{1}_{L-1}) = \frac{1}{1-\frac{1}{4}\alpha_4}(\alpha_3 + \frac{L-2}{2}\alpha_4) = 1$. From (3.15) and the definition of \underline{q}_2^{**} , one sees that $\underline{q}_2^{**T} \underline{1}_L = \underline{w}^T(\alpha_5, \alpha_6) \underline{1}_{L-1} = (L-1)\alpha_5 + (\alpha_6 - \alpha_5) = (L-2)\alpha_5 + \alpha_6$. It then follows from (3.4) and (3.18) that $\underline{q}_2^{**T} \underline{1}_L = (L - \frac{3}{2})a_1 \Delta + \frac{a_1}{a_L} = (\frac{1}{a_1} - \frac{1}{a_L})a_1 + \frac{a_1}{a_L} = 1$. One sees from (3.4), (3.17) and the condition $L > \max\{2, \frac{a_L}{2a_1} + 1\}$ that

$$\begin{aligned} \alpha_4 &= \frac{2\Delta}{\frac{1}{a_1} + \frac{1}{a_L}} = \frac{2}{L - \frac{3}{2}} \frac{a_L - a_1}{a_L + a_1} < \frac{2}{\frac{a_L}{2a_1} + 1 - \frac{3}{2}} \frac{a_L - a_1}{a_L + a_1} \\ &= \frac{4a_1}{a_L - a_1} \frac{a_L - a_1}{a_L + a_1} = 4 \frac{1}{1 + \frac{a_L}{a_1}} < 4. \end{aligned}$$

Hence $\underline{q}_1^{**}, \underline{q}_2^{**} \geq \underline{0}$ and $\underline{q}_1^{**}, \underline{q}_2^{**} \in DRV(\underline{v}_L)$. We next show that $V_1(\underline{e}_m, \underline{q}_2^{**}) \leq V_1(\underline{q}_1^{**}, \underline{q}_2^{**})$ and $V_2(\underline{q}_1^{**}, \underline{e}_m) \leq V_2(\underline{q}_1^{**}, \underline{q}_2^{**})$ hold for all $m \in \mathcal{L}$. From Lemma 3.9 together with (3.15), one easily sees that $\alpha_4 \underline{B}^{-1} \underline{C} \underline{f} + \alpha_3 \underline{B}^{-1} \underline{1}_{L-1} = \alpha_4 \underline{w}(1, 0) + \alpha_3 \underline{w}(0, 1) = \underline{w}(\alpha_4, \alpha_3)$. By Lemma 3.6 this then leads to

$$\alpha_4 \underline{B}^{-1} \underline{C} \underline{f} + \alpha_3 \underline{B}^{-1} \underline{1}_{L-1} = a_1(2 - \alpha_3) \underline{w}(\Delta, \frac{1}{a_L}) = a_1(2 - \alpha_3) \underline{B}^{-1} \underline{A}_D^{-1} \underline{1}_{L-1},$$

where Lemma 3.3 a) is employed to yield the last equality. By multiplying $\underline{A}_D \underline{B}$ from left to the above equation, it follows that $\alpha_4 \underline{A}_D \underline{C} \underline{f} + \alpha_3 \underline{A}_D \underline{1}_{L-1} = a_1(2 - \alpha_3) \underline{1}_{L-1}$, and one has

$$\alpha_4 \underline{A}_D \underline{C} \underline{f} + \alpha_3 \underline{A}_D \underline{1}_{L-1} + \alpha_3 a_1 \underline{1}_{L-1} = 2a_1 \underline{1}_{L-1}. \quad (3.19)$$

Let $x = \frac{4\alpha_3}{4-\alpha_4}$ and $y = \frac{4\alpha_4}{4-\alpha_4}$. One sees that $(L-2)(4-\alpha_4)y = (L - \frac{3}{2} - \frac{1}{2})4 \frac{2\Delta}{\frac{1}{a_1} + \frac{1}{a_L}} = 8 \frac{\frac{1}{a_1} - \frac{1}{a_L}}{\frac{1}{a_1} + \frac{1}{a_L}} - 2 \frac{2\Delta}{\frac{1}{a_1} + \frac{1}{a_L}} = 8 - 8 \frac{\frac{2}{a_L}}{\frac{1}{a_1} + \frac{1}{a_L}} - 2\alpha_4 = 8 - 8\alpha_3 - 2\alpha_4 = 2(4-\alpha_4)(1-x)$, so that $y = \frac{2(1-x)}{L-2}$. Since $\underline{q}_1^{T**} \in DRV(\underline{v}_L)$ and the first component of \underline{q}_1^{T**} is x , one has $0 < x < 1$. Applying

these x and y to Lemma 3.7 and using (3.19), one sees that $\underline{H} \underline{q}_1^{**} = \left[\begin{array}{c} 2a_1 \\ \frac{4}{4-\alpha_4} 2a_1 \underline{1}_{L-1} \end{array} \right]$. This in turn implies that $V_2(\underline{q}_1^{**}, \underline{e}_m) = \underline{e}_m \underline{H} \underline{q}_1^{**} \leq \frac{4}{4-\alpha_4} 2a_1 = V_2(\underline{q}_1^{**}, \underline{q}_2^{**})$ for all $m \in \mathcal{L}$.

We also need to show $V_1(\underline{e}_m, \underline{q}_2^{**}) \leq V_1(\underline{q}_1^{**}, \underline{q}_2^{**})$ for all $m \in \mathcal{L}$. From (3.18) together with (3.15), one sees that

$$\alpha_5 \underline{w}(2, 1) + \underline{w}(0, 2(\alpha_6 - \alpha_5)) = \underline{w}(2\alpha_5, 2\alpha_6 - \alpha_5) = 2a_1 \underline{w}(\Delta, \frac{1}{a_L}). \quad (3.20)$$

Since $\underline{\underline{B}}^{-1}(\underline{\underline{C}} + \underline{\underline{I}}) = (\underline{\underline{I}} + \underline{\underline{L}})^{-1}(\underline{\underline{I}} + 2\underline{\underline{L}} + \underline{\underline{I}}) = 2\underline{\underline{I}}$, Lemma 3.3 a) b) and (3.20) lead to

$$\alpha_5 \underline{\underline{B}}^{-1} \underline{\underline{C}} \underline{\underline{1}}_{L-1} + \underline{\underline{B}}^{-1} (\underline{\underline{C}} + \underline{\underline{I}}) \underline{\underline{w}}(0, \alpha_6 - \alpha_5) = 2a_1 \underline{\underline{B}}^{-1} \underline{\underline{A}}_D^{-1} \underline{\underline{1}}_{L-1} \quad . \quad (3.21)$$

Multiplying $\underline{\underline{A}}_D \underline{\underline{B}}$ from left in (3.21), one obtains $\alpha_5 \underline{\underline{A}}_D \underline{\underline{C}} \underline{\underline{1}}_{L-1} + \underline{\underline{A}}_D (\underline{\underline{C}} + \underline{\underline{I}}) \underline{\underline{w}}(0, \alpha_6 - \alpha_5) = 2a_1 \underline{\underline{1}}_{L-1}$. From the linearity of $\underline{\underline{w}}(x, y)$ in (3.15) and (3.10), this then leads to

$$\begin{aligned} \underline{\underline{A}}_D \underline{\underline{C}} \underline{\underline{w}}(\alpha_5, \alpha_6) &+ \underline{\underline{w}}(0, a_L(\alpha_6 - \alpha_5)) \\ &= \underline{\underline{A}}_D \underline{\underline{C}} \underline{\underline{w}}(\alpha_5, \alpha_5) + \underline{\underline{A}}_D \underline{\underline{C}} \underline{\underline{w}}(0, \alpha_6 - \alpha_5) + \underline{\underline{w}}(0, a_L(\alpha_6 - \alpha_5)) \\ &= \underline{\underline{A}}_D \underline{\underline{C}} \underline{\underline{w}}(\alpha_5, \alpha_5) + \underline{\underline{A}}_D \underline{\underline{C}} \underline{\underline{w}}(0, \alpha_6 - \alpha_5) + \underline{\underline{A}}_D \underline{\underline{w}}(0, (\alpha_6 - \alpha_5)) \\ &= \alpha_5 \underline{\underline{A}}_D \underline{\underline{C}} \underline{\underline{1}}_{L-1} + \underline{\underline{A}}_D (\underline{\underline{C}} + \underline{\underline{I}}) \underline{\underline{w}}(0, \alpha_6 - \alpha_5) = 2a_1 \underline{\underline{1}}_{L-1} \quad , \end{aligned}$$

that is,

$$\underline{\underline{A}}_D \underline{\underline{C}} \underline{\underline{w}}(\alpha_5, \alpha_6) = 2a_1 \underline{\underline{1}}_{L-1} - \underline{\underline{w}}(0, a_L(\alpha_6 - \alpha_5)) \quad . \quad (3.22)$$

Let $x = \alpha_5$ and $y = \alpha_6$ so that $x(L-2) = a_1 \Delta(L-2) = a_1 \Delta(L - \frac{3}{2} - \frac{1}{2}) = (1 - \frac{a_1}{a_L}) - a_1 \frac{\Delta}{2} = 1 - \alpha_6 = 1 - y$, and therefore $x = (1 - y)/(L - 2)$. From (3.18) with (3.4) and the condition $L > 2$, one has

$$y = \alpha_6 = a_1 \left(\frac{1}{a_L} + \frac{\Delta}{2} \right) = \frac{a_1}{a_L} + \frac{a_1}{2} \frac{1 - \frac{1}{a_L}}{L - \frac{3}{2}} < \frac{a_1}{a_L} + \frac{1 - \frac{a_1}{a_L}}{2(2 - \frac{3}{2})} = 1 \quad .$$

Hence with x and y above, Lemma 3.8 can be applied, yielding

$$\underline{\underline{H}} \underline{\underline{q}}_2^{**} = \underline{\underline{H}} \begin{bmatrix} 0 \\ \underline{\underline{w}}(\alpha_5, \alpha_6) \end{bmatrix} = \begin{bmatrix} 2a_1 \\ \underline{\underline{A}}_D \underline{\underline{C}} \underline{\underline{w}}(\alpha_5, \alpha_6) \end{bmatrix} = \begin{bmatrix} 2a_1 \\ 2a_1 \underline{\underline{1}}_{L-1} - \underline{\underline{w}}(0, a_L(\alpha_6 - \alpha_5)) \end{bmatrix} \quad .$$

It should be noted that from the condition $L > \frac{a_L}{2a_1} + 1$, one has $\alpha_6 - \alpha_5 = \frac{a_1}{a_L} - \frac{a_1 \Delta}{2} = \frac{a_1}{a_L} - \frac{1 - \frac{a_1}{a_L}}{2(L - \frac{3}{2})} > \frac{a_1}{a_L} - \frac{1 - \frac{a_1}{a_L}}{2(\frac{a_L}{2a_1} + 1 - \frac{3}{2})} = \frac{a_1}{a_L} - \frac{1 - \frac{a_1}{a_L}}{\frac{a_L}{a_1} - 1} = 0$, so that $V_1(\underline{\underline{e}}_m, \underline{\underline{q}}_2^{**}) \leq 2a_1 = V_1(\underline{\underline{q}}_1^{**}, \underline{\underline{q}}_2^{**})$ for all $m \in \mathcal{L}$, where $(\underline{\underline{q}}_1^{**})_L = 0$ if L is even is employed to yield the last equality. \square

It should be noted that Theorem 3.10 proves the existence of two equilibria $(\underline{\underline{q}}^\#, \underline{\underline{q}}^\dagger)$ and $(\underline{\underline{q}}^\dagger, \underline{\underline{q}}^\#)$. The former one can be written as $\underline{\underline{q}}_1^{**} (= \underline{\underline{q}}^\#) = \frac{4}{4 - \alpha_4} [\alpha_3, \alpha_4 \underline{\underline{f}}^T]^T$ and $\underline{\underline{q}}_2^{**} (= \underline{\underline{q}}^\dagger) = [0, \alpha_5, \dots, \alpha_5, \alpha_6]^T$ while those in Theorem 3.5 are $\underline{\underline{q}}_1^* = \underline{\underline{q}}_2^* (= \underline{\underline{q}}^*) = [\alpha_1, \alpha_2 \underline{\underline{1}}_{L-1}^T]^T$. As we will see, one has $\lim_{L \rightarrow \infty} \underline{\underline{q}}^* = \lim_{L \rightarrow \infty} \underline{\underline{q}}^\#$, while $\lim_{L \rightarrow \infty} \underline{\underline{q}}^\dagger$ is quite different. The supplier with $\underline{\underline{q}}_1^{**} (= \underline{\underline{q}}^\#)$ is risk-averse with tendency to protect the near customer by offering lower prices with higher probabilities, while the supplier with $\underline{\underline{q}}_2^{**} (= \underline{\underline{q}}^\dagger)$ is risk-taking, by offering higher prices with higher probabilities. It may be worthwhile to note that we have constructed the three Nash equilibria $(\underline{\underline{q}}^*, \underline{\underline{q}}^*)$, $(\underline{\underline{q}}^\#, \underline{\underline{q}}^\dagger)$ and $(\underline{\underline{q}}^\dagger, \underline{\underline{q}}^\#)$, which is consistent with the result of Lemke [6] that the number of Nash equilibria of the nondegenerate bimatrix game is odd.

4. Limit Theorems of Nash Equilibria with Specific Discrete Support

In the previous section, three Nash equilibria $(\underline{\underline{q}}^*, \underline{\underline{q}}^*)$, $(\underline{\underline{q}}^\#, \underline{\underline{q}}^\dagger)$ and $(\underline{\underline{q}}^\dagger, \underline{\underline{q}}^\#)$ are constructed explicitly, when the strategy set consists of L discrete supporting points for pricing with

$\underline{v}_L = [v_{L:1}, \dots, v_{L:L}]$ as given in (3.6), where we write each component of \underline{v}_L as $[v_{L:1}, \dots, v_{L:L}]$ instead of $[v_1, \dots, v_L]$ throughout this section to emphasize the demension of \underline{v}_L . While \underline{v}_L partitions the strategy set $I = [c_{high}, U]$ of the original problem in a rather peculiar way as shown in Figure 3.1, the set $\{\underline{v}_L : L = L_0, L_0 + 1, \dots\}$ with $L_0 > 2$ becomes dense in $I = [c_{high}, U]$. Let X_L^*, X_L^\sharp and X_L^\dagger be discrete random variables associated with $\underline{q}^*, \underline{q}^\sharp$ and \underline{q}^\dagger respectively. It is then of interest to see whether or not $(X_L^*, X_L^*), (X_L^\sharp, X_L^\dagger)$ and $(X_L^\dagger, X_L^\sharp)$ in $S(\underline{v}_L) = DRV(\underline{v}_L) \times DRV(\underline{v}_L)$ converge to any mixed strategies $(X^*, X^*), (X^\sharp, X^\dagger)$ and (X^\dagger, X^\sharp) in $S = RV \times RV$ of the original problem as $L \rightarrow \infty$ and those limiting strategies are again Nash equilibriums.

In order to understand such limiting behaviors, we give a preliminary lemma where a proof is provided in Appendix. With the assumption that L is even, $\tilde{L} \stackrel{def}{=} L/2$ is a natural number. In the remainder of this section we write $\tilde{L} \rightarrow \infty$ instead of $L \rightarrow \infty$ to clarify that L moves toward infinity in a set of even numbers.

Lemma 4.1 *Let $F_\infty^*(x)$ be a distribution function defined on $[c_{high}, U]$ given by*

$$F_\infty^*(x) = \alpha_{1:\infty} + \frac{(1 - \alpha_{1:\infty})}{KD} \left(\frac{1}{c_{high} - c_{mid}} - \frac{1}{x - c_{mid}} \right), \quad (4.1)$$

with $\alpha_{1:\infty} = \lim_{\tilde{L} \rightarrow \infty} \alpha_1 (= \frac{2a_1}{a_1 + a_L})$, and define $r_{L:m}^* \stackrel{def}{=} \sum_{m'=1}^m q_{L:m'}^*$ where $\underline{q}^* = [q_{L:1}^*, \dots, q_{L:L}^*]^T$ is as in Theorem 3.5. Then one has

$$\begin{aligned} a) \quad & F_\infty^*(v_{L:m}) < r_{L:m+1}^* \quad , \quad m = 1, \dots, L-1 \quad , \quad \text{and} \\ b) \quad & r_{L:m}^* < F_\infty^*(v_{L:m}) \quad , \quad m = 1, \dots, L-1 \quad . \end{aligned}$$

Theorem 4.2 *Let (Ω, \mathcal{F}, P) be a probability space where $\Omega = (0, 1]$, \mathcal{F} is a Borel field on $\Omega = (0, 1]$ and P is the one-dimensional uniform probability measure on (Ω, \mathcal{F}) , and define $\{\Omega_{L:m}^*\}, m \in \mathcal{L}$ as a partition of Ω given by*

$$\begin{aligned} \Omega_{L:1}^* &= (0, r_{L:1}^*] ; \quad \text{and} \\ \Omega_{L:m}^* &= (r_{L:m-1}^*, r_{L:m}^*] \quad , \quad m = 2, \dots, L \quad . \end{aligned} \quad (4.2)$$

We also define random variables $X^*(\omega) \in RV$ and $X_L^*(\omega) \in DRV(\underline{v}_L)$ on (Ω, \mathcal{F}, P) as

$$\begin{aligned} X_L^*(\omega) &= v_{L:m} \quad \text{if} \quad \omega \in \Omega_{L:m}^* \quad , \quad m = 1, 2, \dots, L \\ X^*(\omega) &= \begin{cases} v_{L:1} & \text{if} \quad \omega \in (0, \alpha_{1:\infty}] \\ F_\infty^{*-1}(\omega) & \text{if} \quad \omega \in (\alpha_{1:\infty}, 1] \end{cases} . \end{aligned}$$

Then the following statements hold.

- 1) $F_\infty^*(x)$ is the distribution function of $X^*(\omega)$
- 2) \underline{q}^* is the probability vector of $X_L^*(\omega)$ where \underline{q}^* is as in Theorem 3.5
- 3) $X_L^*(\omega) \xrightarrow{a.e.} X^*(\omega)$ as $\tilde{L} \rightarrow \infty$

where “ $\xrightarrow{a.e.}$ ” denotes the almost everywhere convergence.

Proof: From the definition of $X^*(\omega)$, one has $P[X^*(\omega) \leq x] = P[\omega \in (0, \alpha_{1:\infty}] \vee (\alpha_{1:\infty} < \omega \leq F_\infty^*(x))] = P[0 < \omega \leq F_\infty^*(x)]$. Since P is the one-dimensional uniform probability measure on (Ω, \mathcal{F}) , one has $P[0 < \omega \leq F_\infty^*(x)] = F_\infty^*(x)$, proving 1). For part 2), from the definition of $X_L^*(\omega)$, one has $P[X_L^*(\omega) = v_{L:m}] = P[\omega \in \Omega_{L:m}^*] = P[r_{L:m-1}^* < \omega \leq r_{L:m}^*] = q_{L:m}^*$. In order to prove part 3), we consider the following four cases:

Case1: $\omega \in \Omega_{L:1}^*$

From the definition of $X_L^*(\omega)$ one has $X_L^*(\omega) = v_{L:1}$. From lemma 4.1 b), one has $r_{L:1}^* < F_\infty^*(v_{L:1}) = \alpha_{1:\infty}$ so that $\Omega_{L:1}^* \subset (0, \alpha_{1:\infty}]$. Then from the definition of $X^*(\omega)$, it is clear that $X^*(\omega) = v_{L:1} = X_L^*(\omega)$.

Case2: $\omega \in \Omega_{L:2}^*$

From the definition of $X_L^*(\omega)$ one has $X_L^*(\omega) = v_{L:2}$. Since $\omega \in \Omega_{L:2}^*$, one has $\omega \leq r_{L:2}^*$. It then follows from the definition of $X^*(\omega)$ that $v_{L:1} \leq X^*(\omega) \leq F_\infty^{*-1}(\omega) \leq F_\infty^{*-1}(r_{L:2}^*)$, where the last inequality is yielded since $F_\infty^*(x)$ is monotonically increasing. From Lemma 4.1 a), one has $F_\infty^{*-1}(r_{L:2}^*) < v_{L:3}$. These observations imply that $|X^*(\omega) - X_L^*(\omega)| < |v_{L:3} - v_{L:1}|$.

Case3: $\omega \in \Omega_{L:m}^*$, $m = 3, \dots, L-1$

From the definition of $X_L^*(\omega)$ one has $X_L^*(\omega) = v_{L:m}$. We note from Lemma 4.1 a) that $\alpha_{1:\infty} = F_\infty^*(v_{L:1}) < r_{L:2}^*$ and it is clear from the condition of this case that $r_{L:2}^* < \omega$ so that $\alpha_{1:\infty} < \omega$. It then follows from this and $\omega \in \Omega_{L:m}^*$ together with the definition of $X^*(\omega)$ that $F_\infty^{*-1}(r_{L:m-1}^*) < X^*(\omega) \leq F_\infty^{*-1}(r_{L:m}^*)$. Similarly as in Case2 we have $v_{L:m-2} < F_\infty^{*-1}(r_{L:m-1}^*)$ and $F_\infty^{*-1}(r_{L:m}^*) < v_{L:m}$ for $m = 3, \dots, L-1$. Then we obtain that $|X^*(\omega) - X_L^*(\omega)| < |v_{L:m} - v_{L:m-2}|$ for $m = 3, \dots, L-1$.

Case4: $\omega \in \Omega_{L:L}^*$

From the definition of $X_L^*(\omega)$, one has $X_L^*(\omega) = v_{L:L}$. Since $\omega \in \Omega_{L:L}^*$, it then follows from the definition of $X^*(\omega)$ that $F_\infty^{*-1}(r_{L:L-1}^*) < X^*(\omega) \leq F_\infty^{*-1}(r_{L:L}^*) = v_{L:L} = U$. From Lemma 4.1 a), we have $v_{L:L-2} < F_\infty^{*-1}(r_{L:L-1}^*)$. Then we obtain that $|X^*(\omega) - X_L^*(\omega)| < |v_{L:L} - v_{L:L-2}|$.

Since $|v_{L:m+1} - v_{L:m-1}| < |v_{L:L} - v_{L:L-2}|$ for all $m = 2, \dots, L-1$, one has that $|X^*(\omega) - X_L^*(\omega)| < |v_{L:L} - v_{L:L-2}|$ for all $\omega \in \Omega$. Since $|v_{L:L} - v_{L:L-2}| \rightarrow 0$ as $\tilde{L} \rightarrow \infty$, it then follows for all $\omega \in \Omega$ that $X_L^*(\omega) \rightarrow X^*(\omega)$ as $\tilde{L} \rightarrow \infty$. \square

A similar theorem can be shown concerning the limiting behavior of X_L^\dagger in Theorem 3.10 when $\tilde{L} \rightarrow \infty$. As before a preliminary lemma is needed and a proof is given in Appendix.

Lemma 4.3 Let $F_\infty^\dagger(x)$ be a distribution function defined on $[c_{high}, U]$ given by

$$F_\infty^\dagger(x) = \begin{cases} \frac{(1 - \alpha_{6:\infty})}{KD} \left(\frac{1}{c_{high} - c_{mid}} - \frac{1}{x - c_{mid}} \right) & \text{if } c_{high} \leq x < U \\ 1 & \text{if } x = U \end{cases}, \quad (4.3)$$

where $\alpha_{6:\infty} \stackrel{def}{=} \lim_{\tilde{L} \rightarrow \infty} \alpha_6 (= \frac{a_1}{a_L})$ and define $r_{L:m}^\#$ and $r_{L:m}^\dagger$ as $r_{L:m}^\# = \sum_{m'=1}^m q_{L:m'}^\#$ and $r_{L:m}^\dagger = \sum_{m'=1}^m q_{L:m'}^\dagger$ where $\mathbf{q}^\dagger = [q_{L:1}^\dagger, \dots, q_{L:L}^\dagger]^T$ and $\mathbf{q}^\# = [q_{L:1}^\#, \dots, q_{L:L}^\#]^T$ are as in Theorem 3.10. As before we assume that L is even. Then one has

- a) $F_\infty^*(v_{L:m}) < r_{L:m}^\#$, $m = 1, 3, 5, \dots, L-1$;
- b) $r_{L:m}^\# < F_\infty^*(v_{L:m+2})$, $m = 1, 3, 5, \dots, L-3$;
- c) $F_\infty^\dagger(v_{L:m}) < r_{L:m}^\dagger$, $m = 1, 2, 3, \dots, L-1$; and
- d) $r_{L:m}^\dagger < F_\infty^\dagger(v_{L:m+2})$, $m = 1, 2, 3, \dots, L-3$.

Theorem 4.4 Let (Ω, \mathcal{F}, P) be a probability space as in Theorem 4.2, and define $\{\Omega_{L:m}^\sharp\}$ and $\{\Omega_{L:m}^\dagger\}$ for $m \in \mathcal{L}$ as partitions of Ω . More specifically we define $\{\Omega_{L:m}^\sharp\}$ and $\{\Omega_{L:m}^\dagger\}$ as

$$\begin{aligned}\Omega_{L:1}^\sharp &= (0, r_{L:1}^\sharp], \\ \Omega_{L:m}^\sharp &= (r_{L:m-1}^\sharp, r_{L:m}^\sharp] \quad m = 2, \dots, L; \quad \text{and} \\ \Omega_{L:1}^\dagger &= (0, r_{L:1}^\dagger], \\ \Omega_{L:m}^\dagger &= (r_{L:m-1}^\dagger, r_{L:m}^\dagger] \quad m = 2, \dots, L, \end{aligned}$$

where $r_{L:m}^\sharp$ and $r_{L:m}^\dagger$ are as in Lemma 4.3. We also define random variables $X^\dagger(\omega) \in RV$ and $X_L^\sharp(\omega), X_L^\dagger(\omega) \in DRV(\underline{v}_L)$ on (Ω, \mathcal{F}, P) as

$$\begin{aligned}X_L^\sharp(\omega) &= v_{L:m} \quad \text{if } \omega \in \Omega_{L:m}^\sharp, \quad m = 1, 2, \dots, L \\ X_L^\dagger(\omega) &= v_{L:m} \quad \text{if } \omega \in \Omega_{L:m}^\dagger, \quad m = 1, 2, \dots, L \\ X^\dagger(\omega) &= \begin{cases} F_\infty^{\dagger-1}(\omega) & \text{if } \omega \in (0, 1 - \alpha_{6:\infty}] \\ v_{L:L} & \text{if } \omega \in (1 - \alpha_{6:\infty}, 1] \end{cases} \end{aligned}$$

Then, with notation of Theorem 3.10, one has

- 1) $F_\infty^\dagger(x)$ is the distribution function of $X^\dagger(\omega)$;
- 2) \underline{q}^\sharp is the probability vector of $X_L^\sharp(\omega)$;
- 3) \underline{q}^\dagger is the probability vector of $X_L^\dagger(\omega)$;
- 4) $X_L^\sharp(\omega) \xrightarrow{a.e.} X^*(\omega)$ as $\tilde{L} \rightarrow \infty$; and
- 5) $X_L^\dagger(\omega) \xrightarrow{a.e.} X^\dagger(\omega)$ as $\tilde{L} \rightarrow \infty$.

Proof: 1),2) and 3) can be proven similarly to Theorem 4.2. In order to prove part 4), we consider the following cases:

Case1: $\omega \in \Omega_{L:1}^\sharp \cup \Omega_{L:2}^\sharp$

From the definition of $X^*(\omega)$, one has either $X^*(\omega) = v_{L:1} (= c_{high} \leq F_\infty^{*-1}(\omega))$ or $X^*(\omega) = F_\infty^{*-1}(\omega)$ so that $X^*(\omega) \leq F_\infty^{*-1}(\omega)$. Since $\omega \leq r_{L:2}^\sharp$ and $F_\infty^*(x)$ is monotonically increasing, one has $F_\infty^{*-1}(\omega) \leq F_\infty^{*-1}(r_{L:2}^\sharp)$. It then follows that

$$X^*(\omega) \leq F_\infty^{*-1}(r_{L:2}^\sharp) \quad . \quad (4.4)$$

From Lemma 4.3 b), one has $r_{L:3}^\sharp < F_\infty^*(v_{L:5})$ so that $F_\infty^{*-1}(r_{L:3}^\sharp) < v_{L:5}$. Since $F_\infty^{*-1}(r_{L:2}^\sharp) < F_\infty^{*-1}(r_{L:3}^\sharp)$, this and (4.4) imply that $X^*(\omega) < v_{L:5}$. It is clear from the definition of $X^*(\omega)$ that $v_{L:1} \leq X^*(\omega)$. These observations imply

$$v_{L:1} \leq X^*(\omega) < v_{L:5} \quad . \quad (4.5)$$

From the definition of $X_L^\sharp(\omega)$, one has $v_{L:1} \leq X_L^\sharp(\omega) \leq v_{L:2}$. This together with (4.5) leads to

$$|X^*(\omega) - X_L^\sharp(\omega)| \leq |v_{L:5} - v_{L:1}| \quad . \quad (4.6)$$

Case2: $\omega \in \Omega_{L:m}^\sharp$ and $m = 4, 6, 8, \dots, L-4$.

From the definition of $F_\infty^*(x)$, one has $\alpha_{1:\infty} = F_\infty^*(v_{L:1}) < F_\infty^*(v_{L:3})$. Since Lemma 4.3 a) implies $F_\infty^*(v_{L:3}) < r_{L:3}^\sharp$, one has $\alpha_{1:\infty} < r_{L:3}^\sharp$ and consequently $\alpha_{1:\infty} < \omega$. Hence from the definition of $X^*(\omega)$, one has $X^*(\omega) = F_\infty^{*-1}(\omega)$. Since $r_{L:m-1}^\sharp < \omega \leq r_{L:m}^\sharp$, it then follows that

$$F_\infty^{*-1}(r_{L:m-1}^\sharp) < F_\infty^{*-1}(\omega) = X^*(\omega) \leq F_\infty^{*-1}(r_{L:m}^\sharp) \quad . \quad (4.7)$$

From Lemma 4.3 a), one has $v_{L:m-1} < F_\infty^{*-1}(r_{L:m-1}^\sharp)$ for $m = 4, 6, 8, \dots, L-4$. From this and (4.7), it can be seen that

$$v_{L:m-1} < F_\infty^{*-1}(r_{L:m-1}^\sharp) < X^*(\omega) \quad \text{for } m = 4, 6, \dots, L-4 \quad . \quad (4.8)$$

From Lemma 4.3 b), one has $F_\infty^{*-1}(r_{L:m+1}^\sharp) < v_{L:m+3}$ for $m = 4, 6, \dots, L-4$. It then follows from this and (4.7) that

$$X^*(\omega) \leq F_\infty^{*-1}(r_{L:m}^\sharp) < F_\infty^{*-1}(r_{L:m+1}^\sharp) < v_{L:m+3} \quad \text{for } m = 4, 6, \dots, L-4 \quad . \quad (4.9)$$

From the definition of $X_L^\sharp(\omega)$, it is clear that $X_L^\sharp(\omega) = v_{L:m}$. This together with (4.8) and (4.9), one has

$$|X^*(\omega) - X_L^\sharp(\omega)| \leq |v_{L:m+3} - v_{L:m-1}| \quad \text{for all } m = 4, 6, \dots, L-4 \quad . \quad (4.10)$$

Case3: $\omega \in \Omega_{L:m}^\sharp$ and $m = 3, 5, 7, \dots, L-3$.

From the definition of $r_{L:m}^\sharp$ and $q_{L:m}^\sharp$ one has $q_{L:m}^\sharp = 0, m = 3, 5, 7, \dots, L-3$ so that $\Omega_{L:m}^\sharp = \emptyset$ for $m = 3, 5, 7, \dots, L-3$.

Case4: $\omega \in \Omega_{L:L-2}^\sharp \cup \Omega_{L:L-1}^\sharp \cup \Omega_{L:L}^\sharp$.

Since $r_{L:L-3}^\sharp < \omega$, one has $F_\infty^{*-1}(r_{L:L-3}^\sharp) \leq F_\infty^{*-1}(\omega) (= X^*(\omega))$. From Lemma 4.3 a), it can be seen that $v_{L:L-3} < F_\infty^{*-1}(r_{L:L-3}^\sharp)$ and therefore

$$v_{L:L-3} < X^*(\omega) \quad . \quad (4.11)$$

From the condition of this case, one has

$$v_{L:L-2} \leq X_L^\sharp(\omega) \quad . \quad (4.12)$$

It is clear from the definition that $X^*(\omega), X_L^\sharp(\omega) \leq v_{L:L}$. This together with (4.11) and (4.12) leads to

$$|X^*(\omega) - X_L^\sharp(\omega)| < |v_{L:L} - v_{L:L-3}| \quad . \quad (4.13)$$

From the definition of $v_{L:m}$, it is clear that $|v_{L:m} - v_{L:m-4}| < |v_{L:L} - v_{L:L-4}|$ for $m = 5, 6, \dots, L$. From this together with (4.6) (4.10) and (4.13), one sees, for all $\omega \in \Omega$, $|X^*(\omega) - X_L^\sharp(\omega)| < |v_{L:L} - v_{L:L-4}|$. Since $\lim_{\tilde{L} \rightarrow \infty} |v_{L:L} - v_{L:L-4}| = 0$, it then follows for all $\omega \in \Omega$ that $X_L^\sharp(\omega) \rightarrow X^*(\omega)$ as $\tilde{L} \rightarrow \infty$, proving part 4).

Finally we prove part 5). As before we consider the following three cases:

Case1: $\omega \in \Omega_{L:1}^\dagger \cup \Omega_{L:2}^\dagger$.

Since $\omega \leq r_{L:2}^\dagger$ and $F_\infty^\dagger(x)$ is monotonically increasing function, one has

$$F_\infty^{\dagger-1}(\omega) \leq F_\infty^{\dagger-1}(r_{L:2}^\dagger) \quad . \quad (4.14)$$

From the definition of $r_{L:m}^\dagger, \alpha_5$ and $\alpha_{6:\infty}$, one sees, for $L > 2$, $r_{L:2}^\dagger \leq r_{L:L-1}^\dagger = (L-2)\alpha_5 = (L-2)a_1\Delta = a_1K \frac{L-2}{L-3/2} < a_1K = 1 - \frac{a_1}{a_L} = 1 - \alpha_{6:\infty}$ so that

$$r_{L:2}^\dagger \leq r_{L:L-1}^\dagger < 1 - \alpha_{6:\infty} \quad . \quad (4.15)$$

Hence one has $r_{L:2}^\dagger \in (0, 1 - \alpha_{6:\infty}]$. This with the definition of $X^\dagger(\omega)$ then leads to $X^\dagger(\omega) = F_\infty^{\dagger-1}(\omega)$, and therefore $X^\dagger(\omega) \leq F_\infty^{\dagger-1}(r_{L:2}^\dagger)$ from (4.14). Lemma 4.3 d) yields $F_\infty^{\dagger-1}(r_{L:2}^\dagger) < v_{L:4}$ so that $X^\dagger(\omega) < v_{L:4}$. It is clear from the definition of $X^\dagger(\omega)$ that $v_{L:1} \leq X^\dagger(\omega)$. Finally, these observations imply that

$$v_{L:1} \leq X^\dagger(\omega) < v_{L:4} \quad . \quad (4.16)$$

From the definition of $X_L^\dagger(\omega)$ it is clear that $v_{L:1} \leq X_L^\dagger(\omega) \leq v_{L:2}$. This together with (4.16) leads to

$$|X^\dagger(\omega) - X_L^\dagger(\omega)| \leq |v_{L:4} - v_{L:1}| \quad . \quad (4.17)$$

Case2: $\omega \in \Omega_{L:m}^\dagger$ and $m = 3, 4, 5, \dots, L-3$.

From the condition of Case2 and (4.15), it is easily seen that $\omega \leq r_{L:L-3}^\dagger < r_{L:L-1}^\dagger < 1 - \alpha_{6:\infty}$, so that $\omega \in (0, 1 - \alpha_{6:\infty}]$. This together with the definition of $X^\dagger(\omega)$ implies that $X^\dagger(\omega) = F_\infty^{\dagger-1}(\omega)$. From the condition of Case2 one has $r_{L:m-1}^\dagger < \omega \leq r_{L:m}^\dagger$, $m = 3, 4, 5, \dots, L-3$ so that

$$F_\infty^{\dagger-1}(r_{L:m-1}^\dagger) < F_\infty^{\dagger-1}(\omega) = X^\dagger(\omega) \leq F_\infty^{\dagger-1}(r_{L:m}^\dagger), \quad m = 3, 4, 5, \dots, L-3 \quad . \quad (4.18)$$

From Lemma 4.3 c), it can be seen that

$$v_{L:m-1} < F_\infty^{\dagger-1}(r_{L:m-1}^\dagger), \quad m = 3, 4, 5, \dots, L-3 \quad . \quad (4.19)$$

From Lemmma 4.3 d) one has $F_\infty^{\dagger-1}(r_{L:m}^\dagger) < v_{L:m+2}$ for $m = 3, 4, 5, \dots, L-3$. From this together with (4.18) and (4.19) one obtains

$$v_{L:m-1} < X^\dagger(\omega) < v_{L:m+2}, \quad m = 3, 4, 5, \dots, L-3 \quad . \quad (4.20)$$

From the definition of $X_L^\dagger(\omega)$, it is clear that $X_L^\dagger(\omega) = v_{L:m}$. This together with (4.20) leads to

$$|X^\dagger(\omega) - X_L^\dagger(\omega)| < |v_{L:m+2} - v_{L:m-1}| \quad . \quad (4.21)$$

Case3: $\omega \in \Omega_{L:L-2}^\dagger \cup \Omega_{L:L-1}^\dagger \cup \Omega_{L:L}^\dagger$.

Since $r_{L:L-3}^\dagger < \omega$ one has

$$F_\infty^{\dagger-1}(r_{L:L-3}^\dagger) < F_\infty^{\dagger-1}(\omega) \quad . \quad (4.22)$$

From the definition of $X^\dagger(\omega)$, either $X^\dagger(\omega) = F_\infty^{\dagger-1}(\omega)$ or $X^\dagger(\omega) = v_{L:L}$. Since $F_\infty^{\dagger-1}(\omega) \leq v_{L:L}$ for all $\omega \in \Omega$, one has $F_\infty^{\dagger-1}(\omega) \leq X^\dagger(\omega)$. From this and (4.22), it follows that $F_\infty^{\dagger-1}(r_{L:L-3}^\dagger) < X^\dagger(\omega)$. It is easily seen from Lemma 4.3 c) that $v_{L:L-3} < F_\infty^{\dagger-1}(r_{L:L-3}^\dagger)$

and therefore $v_{L:L-3} \leq X^\dagger(\omega)$. From the definition of $X^\dagger(\omega)$ it is clear that $X^\dagger(\omega) \leq v_{L:L}$. These observations imply that

$$v_{L:L-3} \leq X^\dagger(\omega) \leq v_{L:L} \quad . \quad (4.23)$$

From the definition of $X_L^\dagger(\omega)$, one sees $v_{L:L-3} < X_L^\dagger(\omega) \leq v_{L:L}$. This together with (4.23) leads to

$$|X^\dagger(\omega) - X_L^\dagger(\omega)| \leq |v_{L:L} - v_{L:L-3}| \quad . \quad (4.24)$$

Since $|v_{L:m} - v_{L:m-3}| \leq |v_{L:L} - v_{L:L-3}|$ for all $m = 4, 5, 6, \dots, L$, from (4.17), (4.21) and (4.24), one has $|X^\dagger(\omega) - X_L^\dagger(\omega)| \leq |v_{L:L} - v_{L:L-3}|$ for all $\omega \in \Omega$. Since $\lim_{\tilde{L} \rightarrow \infty} |v_{L:L} - v_{L:L-3}| = 0$, it then follows that $X_L^\dagger(\omega) \rightarrow X^\dagger(\omega)$ as $\tilde{L} \rightarrow \infty$ for all $\omega \in \Omega$. \square

So far in this section, we have shown that the Nash equilibriums for the descretized game converge almost everywhere to some strategies of the original game. In what follows, we prove that these limiting strategies are also Nash equilibriums for the original game. For this purpose, we need to deal with the limiting behavior of $V_1(X_{1,L}^*, X_{2,L}^*)$. In the remainder of this section, we write $X_{i,L}^*, X_{i,L}^\sharp, X_{i,L}^\dagger$; and $X_i^*, X_i^\dagger, i = 1, 2$ instead of $X_L^*, X_L^\sharp, X_L^\dagger$; and X^*, X^\dagger to emphasize the player of the strategies. Since $h_i(\pi_1, \pi_2)$ in (2.1) is not continuous function of π_1, π_2 , it does not, in general, hold that $\lim_{\tilde{L} \rightarrow \infty} E[h_i(X_L, Y_L)] = E[h_i(X, Y)]$ even if X_L and Y_L converge almost everywhere to X and Y as $\tilde{L} \rightarrow \infty$. As before a preliminary lemma is needed and a proof is provided in Appendix.

Lemma 4.5 *For $i = 1, 2$ let Y_i be any independently and identically distributed (i.i.d.) random variables in RV, and define the associated pairs of i.i.d. random variables $Y_{i,L}$ by*

$$Y_{i,L}(\omega_i) = \begin{cases} v_{L:1} & \text{if } \omega \in \{\omega_i | Y(\omega_i) = v_{L:1}\} \\ v_{L:m} & \text{if } \omega \in \{\omega_i | v_{L:m-1} < Y(\omega_i) \leq v_{L:m}\} \text{ for } m = 2, 3, \dots, L \end{cases} \quad ,$$

where we write ω_i instead of ω to emphasize the player. Then the following statements hold;

- a) $Y_{i,L} \xrightarrow{a.e.} Y_i$ as $\tilde{L} \rightarrow \infty$ for $i = 1, 2$
- b) $\lim_{\tilde{L} \rightarrow \infty} V_i(X_{1,L}^*, X_{2,L}^*) = V_i(X_1^*, X_2^*)$ for $i = 1, 2$
- c) $\lim_{\tilde{L} \rightarrow \infty} V_1(Y_{1,L}, X_{2,L}^*) = V_1(Y_1, X_2^*)$, $\lim_{\tilde{L} \rightarrow \infty} V_2(X_{1,L}^*, Y_{2,L}) = V_2(X_1^*, Y_2)$
- d) $\lim_{\tilde{L} \rightarrow \infty} V_i(X_{1,L}^\sharp, X_{2,L}^\dagger) = V_i(X_1^*, X_2^\dagger)$ for $i = 1, 2$
- e) $\lim_{\tilde{L} \rightarrow \infty} V_1(Y_{1,L}, X_{2,L}^\dagger) = V_1(Y_1, X_2^\dagger)$, $\lim_{\tilde{L} \rightarrow \infty} V_2(X_{1,L}^\sharp, Y_{2,L}) = V_2(X_1^*, Y_2)$

Theorem 4.6 *Let $(X_1^*, X_2^*) \in S$ be as in Theorem 4.2, and $(X_1^\dagger, X_2^\dagger), (X_1^*, X_2^*) \in S$ as in Theorem 4.4. Then one has*

- a) $(X_1^*, X_2^*) \in \mathcal{NE}$; and
- b) $(X_1^*, X_2^\dagger) \in \mathcal{NE}$, $(X_1^\dagger, X_2^*) \in \mathcal{NE}$.

Proof: For any $Y_1 \in S_1$, define $Y_{1,L}$ as in Lemma 4.5. Since $(X_{1,L}^*, X_{2,L}^*) \in \mathcal{NE}(\underline{v}_L)$, one has $V_1(Y_{1,L}, X_{2,L}^*) \leq V_1(X_{1,L}^*, X_{2,L}^*)$ for $L \in \{2, 4, 6, \dots\}$ so that $\lim_{\tilde{L} \rightarrow \infty} V_1(Y_{1,L}, X_{2,L}^*) \leq \lim_{\tilde{L} \rightarrow \infty} V_1(X_{1,L}^*, X_{2,L}^*)$. It then follows from Lemma 4.5 b) and c) that

$$V_1(Y_1, X_2^*) \leq V_1(X_1^*, X_2^*) \quad \text{for all } Y_1 \in S_1 \quad . \quad (4.25)$$

Similarly one has $V_2(X_1^*, Y_2) \leq V_2(X_1^*, X_2^*)$ for all $Y_2 \in S_2 (= RV)$. This together with (4.25) implies that $(X_1^*, X_2^*) \in \mathcal{NE}$, proving part a).

We next prove part b). Since $(X_{1,L}^\#, X_{2,L}^\dagger) \in \mathcal{NE}(\underline{v}_L)$ one has $V_1(Y_{1,L}, X_{2,L}^\dagger) \leq V_1(X_{1,L}^\#, X_{2,L}^\dagger)$ for $L \in \{2, 4, 6, \dots\}$ so that $\lim_{\tilde{L} \rightarrow \infty} V_1(Y_{1,L}, X_{2,L}^\dagger) \leq \lim_{\tilde{L} \rightarrow \infty} V_1(X_{1,L}^\#, X_{2,L}^\dagger)$. It then follows from Lemma 4.5 d) and e) that $V_1(Y_1, X_2^\dagger) \leq V_1(X_1^*, X_2^\dagger)$ for all $Y_1 \in S_1 (= RV)$. Similarly one has $V_2(X_1^*, Y_2) \leq V_2(X_1^*, X_2^\dagger)$ for all $Y_2 \in S_2 (= RV)$, proving that $(X_1^*, X_2^\dagger) \in \mathcal{NE}$. The fact that $(X_1^\dagger, X_2^*) \in \mathcal{NE}$ can be proven in a similar manner, completing the proof. \square

5. Numerical Example

In this section, numerical examples are provided, yielding managerial implications for energy suppliers. We consider the case that two customers are middle-sized industrial cutomers, receiving natural gas transported in LNG lorry tankers. It should be noted that, unlike usual city gas distribution through pipeline networks, the trasportation costs are considered to be marginal costs. Although the price and cost vary depending on the condition and demand pattern, for the sake of convenience, we suppose here $c_{low} = 40$ (Yen/m³), $c_{high} = 50$ (Yen/m³) and $U = 60$ (Yen/m³). For energy supply within this price range, the demand price elasticity is thought to be very small.

The probabilities to win only near customer or both customers are evaluated when

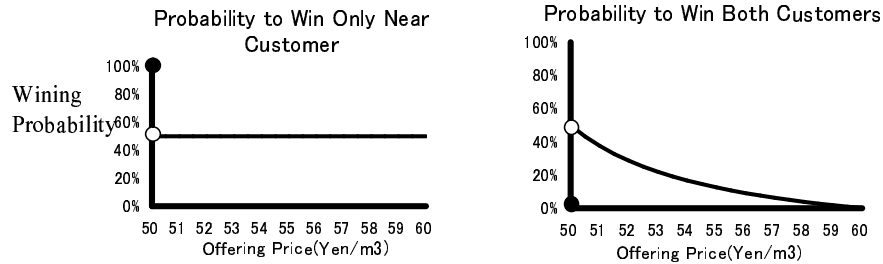

Figure 5.1: Probability to win each customer when $(X_1^*, X_2^*) \in S$

$(X_1^*, X_2^*) \in S$. In our model we assume each player has the same cost structure. If one player tries to secure its near customer while giving up the distance customer, it offers c_{high} since each player provides its service only when it results in a positive return. In this case, the player can capture the customer with probability one. If the player tries to capture both customers, it must offer the price $x > c_{high}$. In this case, the probability to win its near customer is below one since it could lose both customers when the other player offers the price between c_{high} and x . The probability can be written as $F_\infty^*(x) - F_\infty^*(c_{high})$ where F_∞^*

is as in Lemma 4.1. By substituting (3.4), (3.1) and (3.3) into this, one has

$$F_{\infty}^*(x) - F_{\infty}^*(c_{high}) = 1 - \frac{1}{2} \frac{c_{high} - c_{low} + 2d}{c_{high} - c_{low} + d} \left(1 - \frac{c_{high} - c_{low}}{2x - c_{high} - c_{low}}\right) ,$$

where $d \stackrel{def}{=} U - c_{high}$. Figure 5.1 depicts the winning probability for each customer exercising the Nash equilibrium (X_1^*, X_2^*) in Theorem 4.6. Similarly we show in Figure 5.2 the probability for player 1 to win both customers when the equilibrium (X_1^*, X_2^{\dagger}) is realized. This shows that the winning probability for player 1 is 0.2 when it offers the price of U . If player 2 offers the price less than U , then player 1 loses both customers. In other words, player 1 could not capture any demand unless player 2 offers U . The probability for this situation is 0.4. However, in this case the demand is split between them, so that player 1 captures one half of each customer's demand since both players offer the same price U . The above probability 0.2 plotted in Figure 5.2 (expressed in black dot) should be understood in this context. It can be seen that these winning probabilities are nonincreasing as a function of

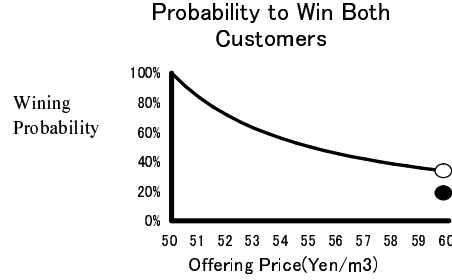

Figure 5.2: Probability to win both customers when $(X_1^*, X_2^{\dagger}) \in S$

price, i.e., the higher the offering price is, the lower the two winning probabilities are. The monotonicity appears in such a way that at the price equilibrium for the mixed strategies, the expected profit is the same regardless of the offering price. However, this does not mean that the offering price is not important. It affects the winning probabilities which may be quite important for assuming the company's presence in the market.

It is worth noting that $X_i^*, i = 1, 2$ in Theorem 4.6 has the mass $m(c_{high}) = 2a_1/(a_1+a_L)$ at c_{high} . Let $U = c_{high} + d$. From (3.1) and (3.2), one then sees that

$$m(c_{high}) = \frac{c_{high} - c_{low}}{c_{high} - c_{low} + d} . \quad (5.1)$$

Adopting the lowest possible price at c_{high} is the risk averse strategy in that the supplier secures the near customer while giving up the distant customer. Equation (5.1) states that the mass assigned to this strategy at the limit is the ratio of the unit profit expected from the near customer under this strategy against that obtained by offering the highest possible price $U = c_{high} + d$. Clearly, the mass $m(c_{high})$ vanishes as $U \rightarrow \infty$ and the associated limiting distribution becomes absolutely continuous on $[c_{high}, \infty)$ having the probability density function given by

$$f_{\infty:U=\infty}(x) = \frac{c_{high} - c_{low}}{2} (x - c_{mid})^{-2} . \quad (5.2)$$

The interpretation for Theorem 4.6 b) can be stated as supplier i takes the risk averse strategy by placing the mass $m_i(c_{high})$ as given in (5.1), while supplier $3 - i$ adopts the risk taking strategy by placing the mass $m_{3-i}(U)$ at the highest possible price U where

$$m_{3-i}(U) = \frac{c_{high} - c_{low}}{c_{high} - c_{low} + 2d} .$$

Both $m_i(c_{high})$ and $m_{3-i}(U)$ diminish to zero as $U \rightarrow \infty$ and one observes again that both suppliers have the same associated limiting strategy specified by (5.2). One may then expect that there exists the unique Nash equilibrium specified by (5.2) with the strategy space $S = RV \times RV$ where RV is the set of all random variables defined on $[c_{high}, \infty)$. This conjecture is currently under study and will be reported elsewhere.

Acknowledgement

This research is supported in part by MEXT Grant-in-Aid for Fundamental Research(C)17510114.

References

- [1] S. Anderson: Spatial competition and price leadership. *International Journal of Industrial Organization*, **5** (1987) 369–398.
- [2] C. D’Aspremont, J. J. Gabszewicz and J. F. Thisse: On Hotelling’s stability in competition. *Econometrica*, **47-5** (1979) 1145–1150.
- [3] N. Economides: Nash equilibrium in duopoly with products defined by two characteristics. *Rand Journal of Economics*, **17-3** (1986) 431–439.
- [4] J. J. Gabszewicz and J. F. Thisse: Location. In: R. J. Aumann and S. Hart(Eds): *Handbook of Game Theory with Economic Applications Vol.1*(North Holland, 1992) 281–304.
- [5] H. Hotelling: Stability in competition. *Economic Journal*, **39** (1929) 41–57.
- [6] C. E. Lemke and J. T. Howson, Jr: Equilibrium points of bimatrix games. *Journal of the Society for Industrial and Applied Mathematics*, **12** (1964) 413–423.
- [7] N. Matsubayashi, M. Umezawa, Y. Masuda and H. Nishino: Evaluating all Bertrand-Nash equilibria in a discrete spatial duopoly model. *Journal of the Operations Research Society of Japan*, **47-1** (2004) 25–37.
- [8] K. P. Rath: Stationary and nonstationary strategies in Hotelling’s model of spatial competition with repeated pricing decisions. *International Journal of Game Theory*, **27** (1998) 525–537.
- [9] J. F. Thisse and X. Vives: On the strategic choice of spatial price policy. *American Economic Review*, **78-1** (1988) 122–137.
- [10] Y. Zhang and Y. Teraoka: A location game of spatial competition. *Mathematica Japonica*, **48-2** (1998) 187–190.

Appendix

Proof of Lemma 3.1: Since $L > 2$, one has $0 < \frac{2}{a_L}(L - 1) + \frac{2}{a_1}(L - 2) = 2(\frac{1}{a_L} + \frac{1}{a_1})(L - \frac{3}{2}) - (\frac{1}{a_1} - \frac{1}{a_L}) = \frac{L - \frac{3}{2}}{a_1} [2(\frac{a_1}{a_L} + 1) - a_1 \Delta] = \frac{L - \frac{3}{2}}{a_1} C_1$, so that $C_1 > 0$. Similarly, since

$L > \frac{a_L}{2a_1} + 1$, it can be seen that $\frac{2}{a_L} - \Delta = \frac{2}{a_L} - \frac{\frac{1}{a_1} - \frac{1}{a_L}}{(L - \frac{3}{2})} = \frac{1}{L - \frac{3}{2}} \left\{ \frac{1}{a_L} (2L - 3) - \frac{1}{a_1} + \frac{1}{a_L} \right\} = \frac{1}{L - \frac{3}{2}} \left\{ \frac{2}{a_L} (L - 1) - \frac{1}{a_1} \right\} = \frac{2}{a_L (L - \frac{3}{2})} \left(L - 1 - \frac{a_L}{2a_1} \right) > 0$. It then follows that $\alpha_1 > 0$ and $\alpha_2 > 0$. Furthermore, one has $\underline{q}^{*T} \underline{1}_L = \alpha_1 + (L - 1)\alpha_2 = \frac{2a_1}{C_1} \left\{ \frac{2}{a_L} - \Delta + (L - 1)\Delta \right\} = \frac{2a_1}{C_1} \left\{ \frac{2}{a_L} - \frac{\Delta}{2} + (L - \frac{3}{2})\Delta \right\} = \frac{2a_1}{C_1} \left\{ \frac{2}{a_L} - \frac{\Delta}{2} + \frac{1}{a_1} - \frac{1}{a_L} \right\} = \frac{1}{C_1} \left(\frac{2a_1}{a_L} + 2 - a_1\Delta \right) = 1$.

Proof of Lemma 3.2: From the definition of Δ , α_1 , α_2 and C_1 , one sees that $2\alpha_2 + a_1(\alpha_1 - 2)\Delta = \frac{2a_1}{C_1} \left[2\Delta + \frac{C_1}{2} \left\{ \frac{2a_1}{C_1} \left(\frac{2}{a_L} - \Delta \right) - 2 \right\} \Delta \right] = \frac{2a_1}{C_1} \Delta \left(2 + \frac{2a_1}{a_L} - a_1\Delta - C_1 \right)$. Substituting $-a_1\Delta = C_1 - \frac{2a_1}{a_L} - 2$ into the last term then yields $\frac{2a_1}{C_1} \Delta \left(2 + \frac{2a_1}{a_L} + C_1 - \frac{2a_1}{a_L} - 2 - C_1 \right) = 0$, proving a). For part b), we first note from a) and the definition of α_2 that $a_1(\alpha_1 - 2) = -\frac{2\alpha_2}{\Delta} = -\frac{4\alpha_1}{C_1}$. We also note that $\alpha_1 + \alpha_2 = \frac{2a_1}{C_1} \left(\frac{2}{a_L} - \Delta + \Delta \right) = \frac{4a_1}{C_1} \frac{1}{a_L}$. It then follows that $\alpha_2 + a_1(\alpha_1 - 2) \frac{1}{a_L} + \alpha_1 = -\frac{4\alpha_1}{C_1} \frac{1}{a_L} + \frac{4\alpha_1}{C_1} \frac{1}{a_L} = 0$, completing the proof.

Proof of Lemma 3.3: We first note that $\underline{L} - \underline{L}_1 = \underline{L}_1 \underline{L}$ so that $(\underline{L} - \underline{L}_1) \underline{B} = \underline{L} - \underline{L}_1 + \underline{L} - \underline{L}_1 \underline{L} = \underline{L}$, and hence $\underline{B}^{-1} = \underline{L} - \underline{L}_1$. From (3.5)(3.10) and (3.12), one then sees that

$$\begin{aligned} \underline{B}^{-1} \underline{A}_D^{-1} \underline{1}_{L-1} &= (\underline{L} - \underline{L}_1) \underline{A}_D^{-1} \underline{1}_{L-1} = \underline{A}_D^{-1} \underline{1}_{L-1} - \underline{L}_1 \underline{A}_D^{-1} \underline{1}_{L-1} \\ &= \begin{bmatrix} \frac{1}{a_2} & & & & \\ & \frac{1}{a_3} & & & \\ & & \ddots & & \\ & & & \frac{1}{a_{L-1}} & \\ \underline{0} & & & & \frac{1}{a_L} \end{bmatrix} \begin{bmatrix} 1 \\ 1 \\ 1 \\ \vdots \\ 1 \end{bmatrix} - \begin{bmatrix} 0 & \frac{1}{a_3} & & & \\ 0 & & \frac{1}{a_4} & & \\ 0 & & & \ddots & \\ 0 & & & & \frac{1}{a_L} \\ 0 & 0 & 0 & \dots & 0 \end{bmatrix} \begin{bmatrix} 1 \\ 1 \\ 1 \\ \vdots \\ 1 \end{bmatrix} \\ &= \begin{bmatrix} \frac{1}{a_2} \\ \frac{1}{a_3} \\ \vdots \\ \frac{1}{a_{L-1}} \\ \frac{1}{a_L} \end{bmatrix} - \begin{bmatrix} \frac{1}{a_3} \\ \frac{1}{a_4} \\ \vdots \\ \frac{1}{a_L} \\ 0 \end{bmatrix} = \begin{bmatrix} \Delta \\ \Delta \\ \vdots \\ \Delta \\ \frac{1}{a_L} \end{bmatrix} = \Delta \underline{1}_{L-1} + \left(\frac{1}{a_L} - \Delta \right) \underline{e}_{L-1}, \end{aligned}$$

where Δ is as in (3.4), proving a). For part b), since $\underline{B}^{-1} = \underline{L} - \underline{L}_1$ and $(\underline{L} - \underline{L}_1) \underline{L} = \underline{L}_1$, it can be seen that $\underline{B}^{-1} \underline{C} \underline{1}_{L-1} = (\underline{L} - \underline{L}_1) (\underline{L} + 2\underline{L}_1) \underline{1}_{L-1} = \{ (\underline{L} - \underline{L}_1) + (2\underline{L} - 2\underline{L}_1 \underline{L}) \} \underline{1}_{L-1} = \underline{L} \underline{1}_{L-1} + \underline{L}_1 \underline{1}_{L-1} = \underline{w}(1, 1) + \underline{w}(1, 0) = \underline{w}(2, 1)$ where $\underline{L} \underline{1}_{L-1} = \underline{w}(1, 1)$ and $\underline{L}_1 \underline{1}_{L-1} = \underline{w}(1, 0)$ are employed to yield the last equality, proving the lemma.

Proof of Lemma 3.4: In what follows, since $\underline{H} = \underline{H}_1$ as in (3.7), any reference to (2.1) assumes $i = 1$. We first note from (3.1) and (3.6) that $v_1 = \frac{a_1}{D} + c_{mid} = \frac{c_{high} - c_{low}}{2} + \frac{c_{high} + c_{low}}{2} = c_{high}$. Hence from (2.1) and (3.1), one has $[\underline{H}]_{1,m} = h_1(v_1, v_m) = h_1(c_{high}, v_m) = (c_{high} - c_{low})D = 2a_1$, proving a). For part b), one sees from (2.1) that $[\underline{H}]_{n,1} = h_1(v_n, v_1) = h_1(v_n, c_{high}) = (v_n - c_{low})D$. Substituting $v_n = \frac{a_n}{D} + c_{mid}$ from (3.6) into the last term and using (3.1), we obtain $(v_n - c_{low})D = a_n + \frac{c_{high} - c_{low}}{2} D = a_n + a_1$. In order to prove part c), we consider the following three cases:

Case1: $1 < m < n \leq L$

For this case, one has $v_m < v_n$ from (3.5) and (3.6) so that it follows from (2.1) that $[\underline{H}]_{m,n} = h(v_m, v_n) = 2(v_m - c_{mid})D = 2\left(\frac{a_m}{D} + c_{mid} - c_{mid}\right)D = 2a_m$.

Case2: $m = n \leq L$

Similarly, for $m = n$, one has $[\underline{H}]_{m,n} = h(v_m, v_n) = (v_m - c_{mid})D = a_m$ for $m \in \mathcal{L} \setminus \{1\}$.

Case3: $L \geq m > n > 1$

In this case, one has $v_m > v_n$ and from (2.1) $[\underline{H}]_{m,n} = 0$.

We note from (3.10) and (3.14) that

$$\underline{\underline{A}}_D \underline{\underline{C}} = \begin{bmatrix} a_2 & 2a_2 & 2a_2 & \cdots & 2a_2 \\ & a_3 & 2a_3 & \cdots & 2a_3 \\ & & a_4 & \cdots & 2a_4 \\ \underline{\underline{0}} & & & \ddots & \vdots \\ & & & & a_L \end{bmatrix}$$

and part c) follows. Part d) is immediate from a), b), and c). Finally we prove part e). Using the result of d), one sees that

$$\begin{aligned} \underline{\underline{H}} \begin{bmatrix} x \\ y \underline{\underline{1}}_{L-1} \end{bmatrix} &= \begin{bmatrix} 2a_1 & 2a_1 \underline{\underline{1}}_{L-1}^T \\ (a_1 \underline{\underline{I}} + \underline{\underline{A}}_D) \underline{\underline{1}}_{L-1} & \underline{\underline{A}}_D \underline{\underline{C}} \end{bmatrix} \begin{bmatrix} x \\ y \underline{\underline{1}}_{L-1} \end{bmatrix} \\ &= \begin{bmatrix} 2a_1 \{x + y(L-1)\} \\ \{a_1 x \underline{\underline{I}} + x \underline{\underline{A}}_D + y \underline{\underline{A}}_D \underline{\underline{C}}\} \underline{\underline{1}}_{L-1} \end{bmatrix} = \begin{bmatrix} 2a_1 \\ \{y \underline{\underline{A}}_D \underline{\underline{C}} + x a_1 \underline{\underline{I}} + x \underline{\underline{A}}_D\} \underline{\underline{1}}_{L-1} \end{bmatrix}. \end{aligned}$$

Proof of Lemma 3.6: By the definition of α_3 in (3.17), one sees that $\alpha_3(1 + \frac{a_1}{a_L}) = 2\frac{a_1}{a_L}$, so that $\alpha_3 = 2\frac{a_1}{a_L} - \frac{a_1}{a_L}\alpha_3 = a_1(2 - \alpha_3)\frac{1}{a_L}$, proving a). For part b), we first note that $2 - \alpha_3 = 2 - \frac{2\frac{a_1}{a_L}}{1 + \frac{a_1}{a_L}} = \frac{2}{1 + \frac{a_1}{a_L}}$. Hence from the definition of α_4 in (3.17), one sees that $\alpha_4 = a_1 \frac{2}{1 + \frac{a_1}{a_L}} \Delta = a_1(2 - \alpha_3)\Delta$, completing the proof.

Proof of Lemma 3.7: From Lemma 3.4 d), one sees that

$$\begin{aligned} \underline{\underline{H}} \begin{bmatrix} x \\ y \underline{\underline{f}} \end{bmatrix} &= \begin{bmatrix} 2a_1 & 2a_1 \underline{\underline{1}}_{L-1}^T \\ (a_1 \underline{\underline{I}} + \underline{\underline{A}}_D) \underline{\underline{1}}_{L-1} & \underline{\underline{A}}_D \underline{\underline{C}} \end{bmatrix} \begin{bmatrix} x \\ y \underline{\underline{f}} \end{bmatrix} = \begin{bmatrix} 2a_1(x + y \frac{L-2}{2}) \\ a_1 x \underline{\underline{I}} \underline{\underline{1}}_{L-1} + x \underline{\underline{A}}_D \underline{\underline{1}}_{L-1} + y \underline{\underline{A}}_D \underline{\underline{C}} \underline{\underline{f}} \end{bmatrix} \\ &= \begin{bmatrix} 2a_1 \\ y \underline{\underline{A}}_D \underline{\underline{C}} \underline{\underline{f}} + a_1 x \underline{\underline{1}}_{L-1} + x \underline{\underline{A}}_D \underline{\underline{1}}_{L-1} \end{bmatrix}, \text{ completing the proof.} \end{aligned}$$

Proof of Lemma 3.8: From Lemma 3.4 d), one sees that $\underline{\underline{H}} \begin{bmatrix} 0 \\ \underline{\underline{w}}(x, y) \end{bmatrix}$

$$= \begin{bmatrix} 2a_1 & 2a_1 \underline{\underline{1}}_{L-1}^T \\ (a_1 \underline{\underline{I}} + \underline{\underline{A}}_D) \underline{\underline{1}}_{L-1} & \underline{\underline{A}}_D \underline{\underline{C}} \end{bmatrix} \begin{bmatrix} 0 \\ \underline{\underline{w}}(x, y) \end{bmatrix} = \begin{bmatrix} 2a_1 \underline{\underline{1}}_{L-1}^T \underline{\underline{w}}(x, y) \\ \underline{\underline{A}}_D \underline{\underline{C}} \underline{\underline{w}}(x, y) \end{bmatrix} = \begin{bmatrix} 2a_1 \\ \underline{\underline{A}}_D \underline{\underline{C}} \underline{\underline{w}}(x, y) \end{bmatrix}$$

where $\underline{\underline{1}}_{L-1}^T \underline{\underline{w}}(x, y) = (L-2)x + y = 1$ is employed to yield the last equality.

Proof of Lemma 3.9: We first note that $(\underline{\underline{I}} - \underline{\underline{L}}_1) \underline{\underline{L}} = \underline{\underline{L}}_1$ and $\underline{\underline{B}}^{-1} = \underline{\underline{I}} - \underline{\underline{L}}_1$ so that $\underline{\underline{B}}^{-1} \underline{\underline{C}} \underline{\underline{f}} = (\underline{\underline{I}} - \underline{\underline{L}}_1)(\underline{\underline{I}} + 2\underline{\underline{L}}) \underline{\underline{f}} = (\underline{\underline{I}} - \underline{\underline{L}}_1 + 2\underline{\underline{L}}_1) \underline{\underline{f}} = (\underline{\underline{I}} + \underline{\underline{L}}_1) \underline{\underline{f}} = \underline{\underline{w}}(1, 0)$, proving part a). For part b), one sees that $\underline{\underline{B}}^{-1} \underline{\underline{1}}_{L-1} = (\underline{\underline{I}} - \underline{\underline{L}}_1) \underline{\underline{1}}_{L-1} = \underline{\underline{1}}_{L-1} - \underline{\underline{w}}(1, 0) = \underline{\underline{w}}(0, 1)$, completing the proof.

Proof of Lemma 4.1: From (3.6) and the definition of $r_{L:m}^*$, $q_{L:m}^*$ and $F_\infty^*(x)$, one has $F_\infty^*(v_{L:m}) - r_{L:m+1}^* = \{\alpha_{1:\infty} + \frac{1-\alpha_{1:\infty}}{K}(\frac{1}{a_1} - \frac{1}{a_m})\} - \{\alpha_1 + m\alpha_2\} = \alpha_{1:\infty} - \alpha_1 + \frac{1-\alpha_{1:\infty}}{K}(\frac{1}{a_1} - \frac{1}{a_m}) - m\alpha_2 = \frac{\Delta}{2} \frac{K'+K}{K'(K'-\frac{\Delta}{2})} + \frac{\Delta}{K'}(m - \frac{3}{2}) - \frac{\Delta}{K'-\frac{\Delta}{2}} m = \frac{\Delta}{2} \frac{1}{K'(K'-\frac{\Delta}{2})} \frac{1}{L-\frac{3}{2}} \{K(L-m) - 2K'(L-\frac{3}{2})\} = \frac{\Delta}{2} \frac{1}{K'(K'-\frac{\Delta}{2})} \frac{1}{L-\frac{3}{2}} \{-\frac{1}{a_1}(L+m-3) - \frac{1}{a_L}(3L-m-3)\} < 0$ for $m = 1, \dots, L-1$, where $K' \stackrel{def}{=} \frac{1}{a_1} + \frac{1}{a_L}$, proving a). One also has $F_\infty^*(v_{L:m}) - r_{L:m}^* = \frac{\Delta}{2} \frac{K'+K}{K'(K'-\frac{\Delta}{2})} + \frac{\Delta}{K'}(m - \frac{3}{2}) - \frac{\Delta}{K'-\frac{\Delta}{2}}(m-1) = \frac{\Delta}{2} \frac{K}{K'(K'-\frac{\Delta}{2})} \frac{L-m}{L-\frac{3}{2}} > 0$, completing the proof.

Proof of Lemma 4.3: From (3.6) and the definition of $r_{L:m}^\sharp$, $q_{L:m}^\sharp$ and $F_\infty^*(x)$, one has,

for $m = 1, 3, 5, \dots, L-1$, $F_\infty^*(v_{L:m}) - r_{L:m}^\# = \alpha_{1:\infty} + \frac{1-\alpha_{1:\infty}}{KD} \left(\frac{1}{c_{high}-c_{mid}} - \frac{1}{v_{L:m}-c_{mid}} \right) - \frac{4}{4-\alpha_4} (\alpha_3 + \frac{m-1}{2} \alpha_4) = \alpha_{1:\infty} + \frac{1-\alpha_{1:\infty}}{K} \left(\frac{1}{a_1} - \frac{1}{a_m} \right) - \frac{4\alpha_3}{4-\alpha_4} - \frac{2(m-1)}{4-\alpha_4} \alpha_4 = \alpha_{1:\infty} - \frac{4\alpha_3}{4-\alpha_4} + \frac{1-\alpha_{1:\infty}}{K} \left(\frac{1}{a_1} - \frac{1}{a_m} \right) - \frac{2(m-1)}{4-\alpha_4} \alpha_4 = \frac{K'-K}{K'} \frac{-\Delta}{2K'-\Delta} + \frac{\Delta}{K'} (m - \frac{3}{2}) - \frac{2\Delta(m-1)}{2K'-\Delta} = \frac{\Delta}{K'(2K'-\Delta)} \{-K' + K + (2K' - \Delta)(m - \frac{3}{2}) - 2K'(m-1)\} = \frac{\Delta}{K'(2K'-\Delta)} \{K \frac{L-m}{L-\frac{3}{2}} - 2K'\} < \frac{\Delta}{K'(2K'-\Delta)} \{2K - 2K'\} < 0$, where $K' \stackrel{def}{=} \frac{1}{a_1} + \frac{1}{a_L}$, proving a). For part b), one also has, for $m = 1, 3, 5, \dots, L-3$, $F_\infty^*(v_{L:m+2}) - r_{L:m}^\# = \alpha_{1:\infty} + \frac{1-\alpha_{1:\infty}}{K} \left(\frac{1}{a_1} - \frac{1}{a_{m+2}} \right) - \frac{4\alpha_3}{4-\alpha_4} - \frac{2(m-1)}{4-\alpha_4} \alpha_4 = \frac{K'-K}{K'} \frac{-\Delta}{2K'-\Delta} + \frac{\Delta}{K'} (m + \frac{1}{2}) - \frac{2\Delta(m-1)}{2K'-\Delta} = \frac{\Delta}{K'(2K'-\Delta)} \{K \frac{L-m-2}{L-\frac{3}{2}} + 2K'\} \geq \frac{\Delta}{K'(2K'-\Delta)} \{K \frac{L-(L-3)-2}{L-\frac{3}{2}} + 2K'\} > \frac{\Delta}{K'(2K'-\Delta)} 2K' > 0$. Next we prove part c). From (3.6) and the definition of $r_{L:m}^\dagger$, $q_{L:m}^\dagger$ and $F_\infty^\dagger(x)$, one has, for $m = 1, 2, 3, \dots, L-1$, $F_\infty^\dagger(v_{L:m}) - r_{L:m}^\dagger = \frac{1-\alpha_{6:\infty}}{KD} \left(\frac{1}{c_{high}-c_{mid}} - \frac{1}{v_{L:m}-c_{mid}} \right) - (m-1)\alpha_5 = \frac{1-(a_1/a_L)}{K} \left(\frac{1}{a_1} - \frac{1}{a_m} \right) - (m-1)\Delta a_1 = a_1 \left(\frac{1}{a_1} - \frac{1}{a_m} \right) - (m-1)\Delta a_1 = a_1 \{K - (L-m)\Delta - (m-1)\Delta\} = a_1 \{(L - \frac{3}{2}) - (L-1)\Delta\} = -\frac{1}{2} a_1 \Delta < 0$. Finally we prove part d). Similarly as in part c), one has, for $m = 1, 2, 3, \dots, L-3$, $F_\infty^\dagger(v_{L:m+2}) - r_{L:m}^\dagger = \frac{1-\alpha_{6:\infty}}{KD} \left(\frac{1}{c_{high}-c_{mid}} - \frac{1}{v_{L:m+2}-c_{mid}} \right) - (m-1)\alpha_5 = \frac{1-(a_1/a_L)}{K} \left(\frac{1}{a_1} - \frac{1}{a_{m+2}} \right) - (m-1)\Delta a_1 = a_1 \left(\frac{1}{a_1} - \frac{1}{a_{m+2}} \right) - (m-1)\Delta a_1 = a_1 \{K - (L-m-2)\Delta - (m-1)\Delta\} = a_1 \{(L - \frac{3}{2})\Delta - (L-3)\Delta\} = \frac{3}{2} a_1 \Delta > 0$, completing the proof.

Proof of Lemma 4.5: We first prove $\lim_{L \rightarrow \infty} V_1(Y_{1,L}, X_{2,L}^\dagger) = V_1(Y_1, X_2^\dagger)$ of c). The other cases can be shown similarly. Let Z^k , $k = 1, \dots, 4$ be defined by $Z^1 = \delta_{\{c_{high} < Y_1 < X_2^\dagger\}}$, $Z^2 = \delta_{\{c_{high} < Y_1 = X_2^\dagger\}}$, $Z^3 = \delta_{\{Y_1 = c_{high}\}}$ and $Z^4 = \delta_{\{X_2^\dagger = c_{high} < Y_1\}}$. Z^k , $k = 1, \dots, 4$ can be defined similarly by replacing Y_1 by $Y_{1,L}$ and X_2^\dagger by $X_{2,L}^\dagger$ respectively. We next prove that $Z_L^k \xrightarrow{a.e.} Z^k$, $k = 1, \dots, 4$. The following six cases, as depicted in Figure A.3, are considered.

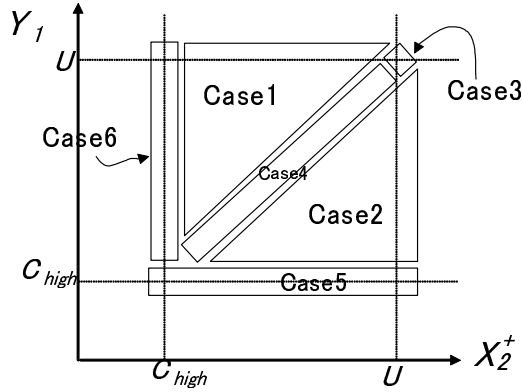

Figure A.3: Image of the cases

Case1: $(\omega_1, \omega_2) \in \{(\omega_1, \omega_2) | [c_{high} < Y_1(\omega_1)] \wedge [c_{high} < X_2^\dagger(\omega_2)] \wedge [Y_1(\omega_1) > X_2^\dagger(\omega_2)]\}$

Let $\epsilon \stackrel{def}{=} Y_1 - X_2^\dagger > 0$. Since $Y_{1,L} \xrightarrow{a.e.} Y_1$ and $X_{2,L}^\dagger \xrightarrow{a.e.} X_2^\dagger$, one has, for sufficiently large N , that $|Y_1 - Y_{1,L}| < \frac{\epsilon}{3}$ and $|X_2^\dagger - X_{2,L}^\dagger| < \frac{\epsilon}{3}$ for $L > N$. It then follows that $\frac{\epsilon}{3} = Y_1 - \frac{\epsilon}{3} - X_2^\dagger - \frac{\epsilon}{3} < Y_1 - (Y_1 - Y_{1,L}) - X_2^\dagger - (X_{2,L}^\dagger - X_2^\dagger) = Y_{1,L} - X_2^\dagger$ for $L > N$. Finally, these observations imply that

$$Z_L^1 = Z^1 = 0 \quad \text{for } L > N \quad ; \quad \text{and} \quad (\text{A.1})$$

$$Z_L^2 = Z^2 = 0 \quad \text{for } L > N \quad . \quad (\text{A.2})$$

From the condition of the Case1, one sees $c_{high}(=v_{L:1}) < Y_1$. It then follows from the definition of $Y_{1,L}$ that $c_{high} < Y_{1,L}$ for all L . Thus one has

$$Z^3 = Z_L^3 = 0 \quad \text{for all } L. \quad (\text{A.3})$$

From the condition of the Case1, one also sees $c_{high} < X_2^\dagger$. Since $\omega_2 \in (0, 1]$, one has $\omega_2 \neq 0$. Hence, from the definition of $X_{2,L}^\dagger$, for sufficiently large N , $c_{high} = v_{L:1} < X_{2,L}^\dagger$, and therefore

$$Z^4 = Z_L^4 = 0 \quad \text{for } L > N. \quad (\text{A.4})$$

Case2: $(\omega_1, \omega_2) \in \{(\omega_1, \omega_2) | [c_{high} < Y_1(\omega_1)] \wedge [c_{high} < X_2^\dagger(\omega_2)] \wedge [Y_1(\omega_1) < X_2^\dagger(\omega_2)]\}$

Let N be sufficiently large number. Then in a similar way as in Case1 it is clear that

$$Z_L^1 = Z^1 = 1, \quad Z_L^2 = Z^2 = 0 \quad \text{for } L > N \quad ; \quad \text{and} \quad (\text{A.5})$$

$$Z^3 = Z_L^3 = 0, \quad Z^4 = Z_L^4 = 0 \quad \text{for all } L. \quad (\text{A.6})$$

Case3: $(\omega_1, \omega_2) \in \{(\omega_1, \omega_2) | Y_1(\omega_1) = X_2^\dagger(\omega_2) = U\}$

From the definition of $Y_{1,L}$ in Lemma 4.5, one sees $Y_{1,L} = U$ for all L . Since $\Delta > 0$ and $\lim_{L \rightarrow \infty} \Delta = 0$, one has $\alpha_{6:\infty} < q_{L:L}^\dagger = \alpha_6 = a_1(\frac{1}{aL} + \frac{\Delta}{2})$, and consequently $(1 - \alpha_{6:\infty}, 1] \subset (1 - q_{L:L}^\dagger, 1] = (r_{L:L-1}^\dagger, r_{L:L}^\dagger]$. Since $X_2^\dagger(\omega_2) = U(=v_{L:L})$, from the definition of X_2^\dagger , one has $\omega_2 \in (1 - \alpha_{6:\infty}, 1]$ so that $\omega_2 \in (r_{L:L-1}^\dagger, r_{L:L}^\dagger]$. It then follows from the definition of $X_{2,L}^\dagger$ that $X_{2,L}^\dagger = v_{L:L} = U$ for all L . These observations imply that

$$[Z^k = Z_L^k = 0, k = 1, 3, 4 ; \text{ and } Z^2 = Z_L^2 = 1] \text{ for all } L. \quad (\text{A.7})$$

Case4: $(\omega_1, \omega_2) \in \{(\omega_1, \omega_2) | c_{high} < Y_1(\omega_1) = X_2^\dagger(\omega_2) < U\}$

Since it is clear that $P[c_{high} < Y_1(\omega_1) = X_2^\dagger(\omega_2) < U] = 0$ we do not have to examine limiting behavior of $Z_L^k, k = 1, \dots, 4$.

Case5: $(\omega_1, \omega_2) \in \{(\omega_1, \omega_2) | Y_1(\omega_1) = c_{high}\}$

From the definition of $Y_{1,L}$ one has $Y_{1,L} = c_{high}$ for all L . Hence it is clear that

$$[Z^k = Z_L^k = 0, k = 1, 2, 4 ; \text{ and } Z^3 = Z_L^3 = 1] \text{ for all } L. \quad (\text{A.8})$$

Case6: $(\omega_1, \omega_2) \in \{(\omega_1, \omega_2) | X_2^\dagger = c_{high} < Y_1(\omega_1)\}$

From the definition of X_2^\dagger , it is clear $P[c_{high} = X_2^\dagger(\omega_2)] = 0$, hence we do not have to examine limiting behavior of $Z_L^k, k = 1, \dots, 4$.

From (A.1), \dots , (A.8), one obtains that $Z_L^k \xrightarrow{a.e.} Z^k$ as $L \rightarrow \infty$ for $k = 1, 2, \dots, 4$. From (2.1), one has $h_1(Y_1, X_2^\dagger) = D\{2(Y_1 - c_{mid})Z^1 + (Y_1 - c_{mid})Z^2 + (c_{high} - c_{low})Z^3 + (Y_1 - c_{low})Z^4\}$. It should be noted that $h_1(Y_1, X_2^\dagger)$ can be written as the continuous function of Y_1, X_2^\dagger and $Z^k, i = 1, \dots, 4$. According to the a) of this Lemma, $Y_{1,L} \xrightarrow{a.e.} Y_1$, and $Z_L^k \xrightarrow{a.e.} Z^k, k = 1, \dots, 4$, as we prove above. Hence one concludes that $\lim_{L \rightarrow \infty} V_1(Y_{1,L}, X_{2,L}^*) = \lim_{L \rightarrow \infty} E[h_1(Y_{1,L}, X_{2,L}^*)] = E[h_1(Y_1, X_2^*)] = V_1(Y_1, X_2^*)$. The other parts of this Lemma can also be shown in the similar way, completing the proof.